



**MILLENNIUM II
Combustible Gas Sensor**

**Infrared Sensor
User Manual**



Model: SC311X-100-ASSY

ISO 9001:2000



**Part Number: MAN-0091 Rev 3
August 27, 2010**

IMPORTANT INFORMATION

This manual is for informational purposes only. Although every effort has been made to ensure the correctness of the information, technical inaccuracies may occur and periodic changes may be made without notice. Net Safety Monitoring Inc., assumes no responsibility for any error contained within this manual.

If the products or procedures are used for purposes other than as described in the manual, without receiving prior confirmation of validity or suitability, Net Safety Monitoring Inc. does not guarantee the results and assumes no obligation or liability. No part of this manual may be copied, disseminated or distributed without the express consent of Net Safety Monitoring Inc.

Net Safety Monitoring Inc. products are carefully designed and manufactured from high quality components and can be expected to provide many years of trouble free service. Each product is thoroughly tested, inspected and calibrated prior to shipment. Failures can occur which are beyond the control of the manufacturer. Failures can be minimized by adhering to the operating and maintenance instructions herein. Where the absolute greatest of reliability is required, redundancy should be designed into the system.

WARRANTY

Net Safety Monitoring Inc warrants this sensor against defective parts and workmanship for a period of 5 years from the date of shipment. No other warranties or liability, expressed or implied, will be honoured by Net Safety Monitoring Inc. Contact Net Safety Monitoring Inc. or an authorized representative for details.

We welcome your input at Net Safety Monitoring Inc. If you have any comments please contact us at the telephone number or address below or visit our web-site, : www.net-safety.com/ and complete our on-line customer survey.

If further language translation for this manual is required please contact:

CONTACT INFORMATION

Net Safety Monitoring Incorporated
Corporate Headquarters
2721 Hopewell Place NE
Calgary, AB Canada T1Y 7J7

Direct: (403) 219-0688
Facsimile: (403) 219-0694
E-mail: nsmsales@net-safety.com
Web-site: www.net-safety.com/

TABLE OF CONTENTS

INTRODUCTION	5
<i>THE PRODUCT</i>	5
<i>THE MANUAL</i>	5
Transmitter and Sensor Enclosure Dimensions	6
SECTION 1: Plan	7
1.1 <i>Locate Sensor</i>	7
1.2 <i>Sensor Non-Separated/direct mounting</i>	7
1.3 <i>Sensor Separated/remote mounting</i>	7
SECTION 2: Installation	8
2.1 <i>Unpack</i>	8
2.2 <i>Mount</i>	8
2.3 <i>Wiring</i>	8
2.3.1 <i>Field Installation</i>	8
<i>Earth Grounding</i>	8
2.3.2 <i>Sensor Wiring</i>	9
2.3.3 <i>Installation Checklist</i>	9
SECTION 3: Operation	10
3.1 <i>Configuration Settings</i>	10
3.2 <i>Sensor Power Up</i>	10
3.3 <i>Sensor Communication</i>	10
SECTION 4: Output	11
4.1 <i>Alarm and Fault Outputs</i>	11
4.1.1 <i>Other Available Outputs</i>	11
4.1.2 <i>Modbus registers</i>	11
SECTION 5: Maintaining	12
5.1 <i>Calibration Procedure</i>	12
5.1.1 <i>Calibrating with the Millennium II Basic Transmitter</i>	12
5.1.2 <i>Calibrating with the Millennium II Transmitter</i>	16
5.1.3 <i>Cross sensitivity</i>	19
5.2 <i>Sensor Replacement Procedure</i>	19
5.3 <i>Troubleshooting</i>	20
5.4 <i>Storage</i>	20
5.5 <i>Spare Parts / Accessories</i>	20
5.6 <i>How to Return Equipment</i>	21

Appendix **22**
Appendix A: Electrostatic Sensitive Device (ESD)..... 22
Appendix B: Resistance Table 23
Appendix C: Millennium II Mini IR Combustible Sensor Specifications..... 24

INTRODUCTION

Infrared (SC311) combustible gas sensors are designed specifically for use with the Millennium II series transmitters. These state of the art “Smart” sensors are both versatile and reliable for fast, accurate and continuous monitoring of gases in extreme environments.

THE PRODUCT

The sensor assembly consists of a factory sealed explosion proof enclosure (housing) rated for hazardous locations and a replaceable combustible sensor module. This sensor should only be used with the Millennium II series transmitters (**Millennium II Basic Transmitter and the Millennium II Transmitter**). If the sensor is connected to any other model transmitter, it will not function and may result in the sensor being damaged.

THE MANUAL

This manual has been designed to ensure the sensor is set-up, operated and maintained properly. **It outlines specific details of the IR sensor and addresses calibration procedures using the Millennium II Basic Transmitter and the Millennium II Transmitter.** If you encounter any problems, see the troubleshooting section of this manual or contact your local representative.

Figure 1: Sensor Dimensional Drawing
Measurements are in inches and millimeters (mm).

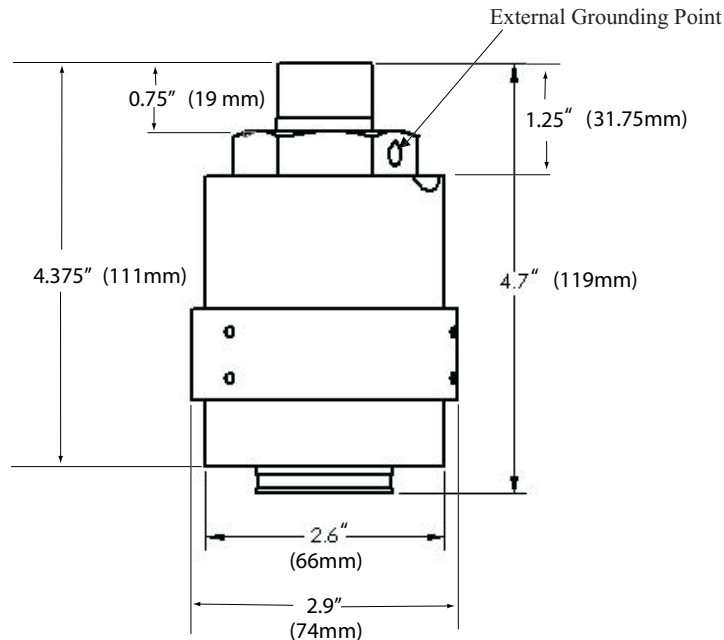

Transmitter and Sensor Enclosure Dimensions

The tables below give the enclosure (housing) dimensions of the Millennium II Transmitter with sensor and Millennium II Basic Transmitter with sensor. Both transmitter and sensor enclosures are offered in Aluminum (AL) and Stainless Steel (SS).

Table 1: Millennium II enclosure and sensor dimensions (A through H) in Inches(in) and Millimeters(mm)

Millennium II transmitter enclosure	A		B		C		D		E		F		G		H	
	in	mm	in	mm	in	mm	in	mm	in	mm	in	mm	in	mm	in	mm
Transmitter & sensor(AL)	6.3	160	5.6	142	5.4	137	9.7	246	6.0	152	5.7	145	2.6	66	2.9	74
Transmitter & sensor(SS)	5.9	150	5.1	130	4.6	117	8.9	226	6.0	152	5.8	147	2.6	66	2.9	74

Table 2: Millennium II Basic enclosure (or junction box enclosure) and sensor dimensions (A through J) in Inches(in) and Millimeters(mm)

Millennium II Basic & sensor	A		B		C		D		E		F		G		H	
	in	mm	in	mm	in	mm	in	mm	in	mm	in	mm	in	mm	in	mm
Transmitter & sensor(AL)	4.8	122	3.6	91	3.6	91	4.8	122	5.1	130	0.3	7.6	2.6	66	2.9	74
Transmitter & sensor(SS)	4.7	119	3.6	91	3.6	91	4.7	119	5.1	130	0.3	7.6	2.6	66	2.9	74

Table 2(cont'd)

Millennium II Basic & sensor	I		J	
	in	mm	in	mm
Transmitter & sensor(AL)	3.0	76	9.0	229
Transmitter & sensor(SS)	2.8	71	8.9	226

Figure 2: Dimensional drawing for sensor with Millennium II series transmitters

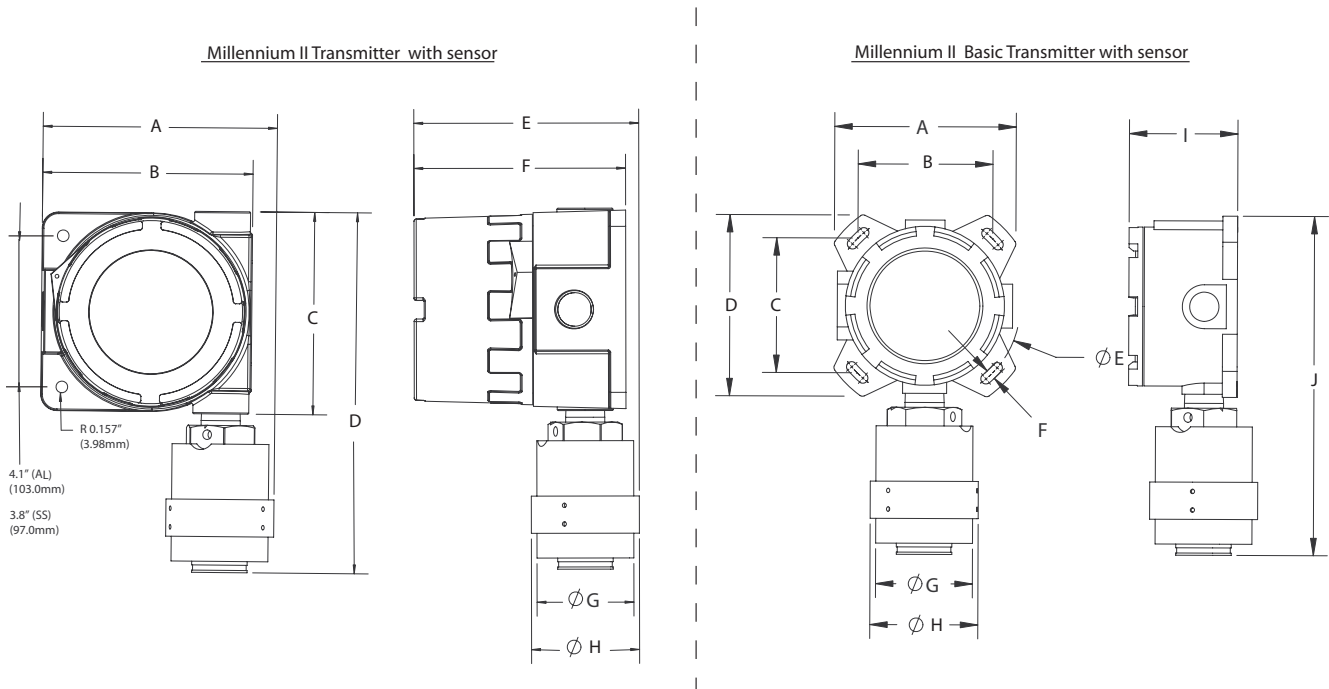

SECTION 1: Plan

1.1 Locate Sensor

Prior to the installation process, a plan should be developed for placement of the sensor. Although there are no absolute rules determining the quantity of detectors or location of a sensor, the following points should be considered when planning the installation.

- Carefully locate the sensor in an area where gases may potentially accumulate. (Remember, light gases tend to rise and heavy gases tend to accumulate in low areas).
- Use redundant systems to enhance protection and reliability.
- Consider the air movement patterns within the facility.
- Consider the construction of the facility such as trenches where heavy gases or peaks where light gases may accumulate.
- Seek advice from experts knowledgeable about the primary gas to be detected.
- Use common sense and refer to the regulatory publications that discuss guidelines for your industry.

1.2 Sensor Non-Separated/direct mounting

The sensor is attached directly to a transmitter and placed in the appropriate location for detecting the gas in question (target gas).

1.3 Sensor Separated/remote mounting

The sensor should always be connected to a certified junction box when separated from transmitter. The transmitter is located near eye-level for easy access and the sensor is mounted where gas is likely to accumulate. A calibration cup is clipped onto the bottom of the sensor enclosure and the calibration tubing is attached to the calibration cup and runs back to a convenient place for applying calibration gas, eliminating the need to access the sensor directly. Calibration gas can then be applied from ground level.

To compensate for the effect of distance when remotely calibrating, in separation configuration, decrease the tubing diameter or increase the calibration gas flow rate between the gas canister and sensor. On initial install, always confirm tubing run is not affecting calibration. Calibrate the sensor using tubing run and then confirm readings directly at sensor by applying calibration gas and comparing the output results. Readings should be accurate to the calibration gas concentration used.

Figure 3: Locating Sensor

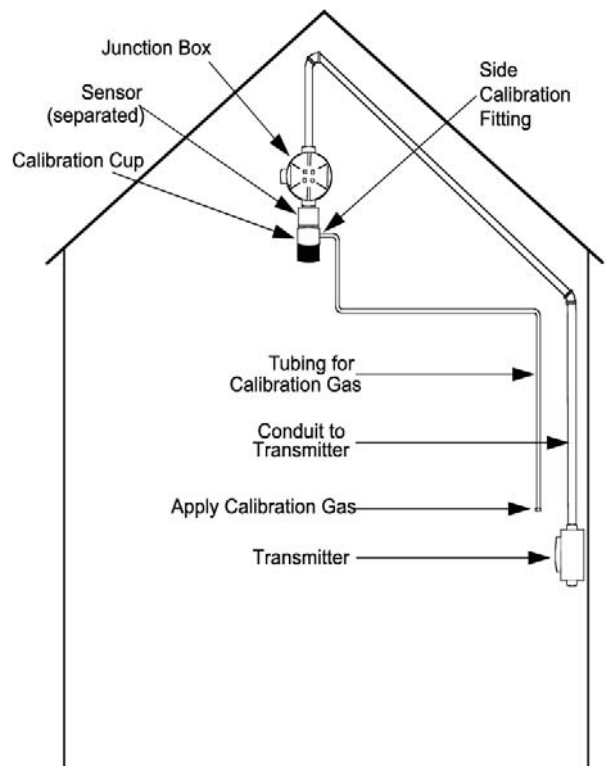

SECTION 2: Installation

2.1 Unpack

Carefully remove all the components from the packaging and check them against the enclosed packing list. Inspect all components for any obvious damage such as broken or loose parts. If you find any components missing or damaged, notify your local Net Safety representative or the factory immediately.

2.2 Mount

Warning  Never install the sensor pointing upwards.

Recommendation: The sensor should be installed pointing downwards.

The sensor is mounted directly to either transmitter enclosure or to a separation junction box enclosure through a 3/4" NPT conduit entry. Both the transmitter and junction box enclosures have mounting holes to allow mounting to a wall or pole as desired. Mounting kit hardware is required when mounting to a pole. Contact your local Net Safety Representative for detailed information on mounting kits.

2.3 Wiring

2.3.1 Field Installation

Warning  Wiring codes and regulations may vary. ATEX requires that supply connection wiring must be rated at least 5°C above the maximum ambient temperature of 85°C. Wiring must comply with all applicable regulations relating to the installation of electrical equipment in a hazardous area and is the responsibility of the installer. If in doubt, consult a qualified official before wiring the system.

Guidelines

When separating sensor from transmitter, the use of shielded cable is highly recommended for sensor wiring to protect against interference caused by extraneous electrical or electromagnetic 'noise'. To meet IEC 61000-1, IEC 61000-4 EMI, follow recommendations on cable choice and guidelines in the specific Millennium II series transmitter manual (MAN-0082 or MAN-0076). In applications where the wiring is installed in conduit, the conduit must not be used for wiring to other electrical equipment.

The maximum distance between the sensor and transmitter is limited by the resistance of the connecting wiring, which is a function of the gauge of the wire being used. Net Safety recommends that sensor separation distance should not be more than 2000 ft with 16 AWG wire. See Appendix B for wire gauges and resistance values.

Earth Grounding

An external ground is required. One method is to connect the external ground to the grounding point on the enclosure. See Figure 1 for grounding connection location.

Conduit Entry

Sensors are mounted directly to transmitters via 3/4" NPT conduit entries through which wires are connected to terminals. Sensors may also be mounted remotely to transmitters using certified junction boxes with designated terminals. Transmitter and junction box enclosures are shipped with one stopping plug fitted and tightened to a 3/4" NPT conduit entry.

MAN-0091 Rev 3 IR Combustible Sensor

August 27, 2010

Net Safety Monitoring Inc.

2.3.2 Sensor Wiring

Warning ⚠ Do not open enclosures in a classified area (Do not open when an explosive atmosphere may be present). Ensure that power to the transmitter is switched off prior to connecting sensor wires.

Warning ⚠ Avoid touching electronic components, as they are susceptible to electrostatic discharge (ESD). Refer to [Appendix A](#), “Electrostatic Sensitive Device (ESD)”.

Connect sensor wires to the sensor terminals in the applicable transmitter. Refer to the [Table 3](#) for sensor terminal definitions.

Table 3: Sensor wires and Millennium II series Terminal definitions

Sensor Terminals	Sensor Wire	White	Red	Blue	Black	Green
	Marked	+VDC	Sig A	Sig B	COM	
	Function	10.5 - 32VDC	A	B	Common/Supply Ground	Earth Ground

NOTE: When separating sensor from transmitter using **Net Safety separation kit**, refer to **Multi-purpose Junction Box Manual (MAN-0081)** for terminal designations. Always ensure that the transmitter is supplying the required voltage to the sensor terminals inside junction box. Refer to table above for sensor voltage requirements.

2.3.3 Installation Checklist

Prior to operation, it is important to do the following:

- Ensure transmitter and sensor are properly and firmly mounted.
- Ensure that stopping plug is tightened to unused conduit entry.
- Ensure transmitter and sensor are not being obstructed; transmitter and sensor are accessible and target gas is not inhibited from reaching sensor.
- ● Remove sensor red protective plastic cap/cover from sensor mouth.
- If IP filters are being used/fitted to sensor, check for damage or debris. Refer to specific IP filter instruction guide (MAN-0109).
- If calibration cup (splash guard) is being used/fitted to sensor, ensure a snug fit.
- Ensure adherence to applicable local guidelines and requirements on wiring and sealing of equipment in hazardous and non-hazardous areas.
- Ensure that proper shielding and grounding practices are adhered to, and local codes are being followed.
- Check system operational voltage and conditions. See [Table 3](#) and Appendix C.
- Check wiring at all termination and junction points; wiring at transmitter terminals, junction box and at power supply. See [Table 3](#) above and specific transmitter manual.

SECTION 3: Operation

3.1 Configuration Settings

All configuration settings are accessed through the Millennium II series transmitters. When using the Millennium II Basic Transmitter, configuration settings are made by setting DIP switches or accessing Modbus registers depending on the model Millennium II Basic Transmitter. For the Millennium II Transmitter, settings are accessed by selecting menu options. Refer to Section '5.1.1: Calibrating with the Millennium II Basic Transmitter' and Section '5.1.2: Calibrating with the Millennium II Transmitter' for information on selecting target gas curves. Also see the relevant transmitter manual for information on Modbus settings.

3.2 Sensor Power Up

When power is applied to the sensors by transmitters, a 90 second warm-up routine will begin, whereby sensors are automatically tested to ensure proper functioning. Refer to the Millennium II Basic Transmitter manual (MAN-0082) or the Millennium II Transmitter manual (MAN-0076) for status indications during this period. It is recommended that these sensors be powered up for 24 hours prior to the first calibration.

3.3 Sensor Communication

SC311 sensors use a proprietary protocol to communicate with the Millennium II series transmitters. These sensors should never be connected to any device other than the Millennium II series transmitters. Selected DIP switches and menu options allow communication between transmitters and sensors. Configuration settings are stored in the sensors' memory. Incorrect settings will cause sensors not to communicate properly with transmitters. If any problems develop see troubleshooting section.

SECTION 4: Output

4.1 Alarm and Fault Outputs

Sensor alarm and fault outputs are generated by the Millennium II series transmitters based on communication with sensors, however some output values, registers, etc, may vary depending on sensor type. **The default alarm levels (points) for the sensor are: 20 % for the low level and 40 % for the high level.**

4.1.1 Other Available Outputs

All available outputs are associated with the Millennium II series transmitters. These outputs are: 4-20 mA output, Relay Output, RS 485 Modbus (RTU) output and HART Communication output. Refer to the Millennium II Basic Transmitter manual (MAN-0082) or the Millennium II Transmitter manual (MAN-0076) for more information.

4.1.2 Modbus registers

Table 4 below shows the user accessible Modbus registers and meaning.

Table 4: Modbus registers and meaning

Reg #	Meaning	Readable	Writeable
40001	Concentration value as calculated by sensor	X	
40002	Sensor status	X	
40003	Sensor Temperature	X	
40009	Select target gas	X	X
40101	Resets the sensor		X
40102	Initialize zero & span *(to calibrate sensor, enter channel #)*		X
40104	Zero only *(to zero sensor, enter channel #)*		X

* **Note:** For the Millennium II Basic Transmitter enter '1' in register 40102 to calibrate the sensor and '1' in register 40104 to zero the sensor.

SECTION 5: Maintaining

5.1 Calibration Procedure

There are specific steps to be followed when calibrating with the Millennium II Basic and the Millennium II Transmitters. These steps should be followed if accurate results are to be obtained. Calibration gas can be air or nitrogen balanced. It is recommended that these sensors be bump tested every 3 months (90 days) to confirm proper response. Calibration of these sensors is required each year to confirm proper functioning.

5.1.1 Calibrating with the Millennium II Basic Transmitter.

When using the **IR sensor with the Millennium II Basic Digital Transmitter Model**, the target gas can be selected or changed by accessing a specific Modbus register. The user should write to register 40009 using the preset single register command 0x06 to change the target gas. The particular target gas is selected by entering the gas curve number that corresponds to the target gas from [Table 5](#) below.

The table below outlines the primary detected gases of this sensor, however, multiple other gases are detectable. Please contact your representative regarding any gases not included in this table.

Table 5: Target Gas with gas curve numbers

Target Gas	Gas Curve Numbers
Methane	0
Propane	1
*n-Butane	2
*Iso-Pentane	3
*n-Pentane	4
Ethane	5
*Iso-Butane	6
Ethylene	7
*Hexane	8

*indicates gases not performance certified

When using the **IR sensor with the Millennium II Basic Analog, Analog HART and Relay Transmitter models**, make use of the transmitter's DIP Switch 2 positions as seen in [Table 6](#) below, to select the target gas, and then follow the Normal Calibration Procedure to perform calibrations. **Use 50% LEL of the specific gas to be detected for calibration.** See example, [Table 6](#) and Full Calibration / Normal Calibration Procedure below. If calibration is not successful perform a manual reset. See Millennium II Basic Manual (MAN-0082) for manual reset.

Example: If the target gas is say, Propane, set Dip Switch 2 position 1 in the ON position and positions, 2, 3 and 4 in the OFF position, this corresponds to Propane (Curve 2), then use 50% LEL Propane for calibration.

Table 6: Millennium II Basic Transmitter DIP Switch 2 positions/combinations

DIP Switch 2				
Position 1	Position 2	Position 3	Position 4	Gas Curves
OFF	OFF	OFF	OFF	Curve 1 (Methane)
ON	OFF	OFF	OFF	Curve 2 (Propane)
OFF	ON	OFF	OFF	* Curve 3 (n-Butane)
ON	ON	OFF	OFF	*Curve 4 (Iso-Pentane)
OFF	OFF	ON	OFF	* Curve 5 (n-Pentane)
ON	OFF	ON	OFF	Curve 6 (Ethane)
OFF	ON	ON	OFF	*Curve 7 (Iso-Butane)
ON	ON	ON	OFF	Curve 8 (Ethylene)
OFF	OFF	OFF	ON	*Curve 9 (Hexane)
ON	OFF	OFF	ON	Curve 10 (TBA)
OFF	ON	OFF	ON	Curve 11 (TBA)
ON	ON	OFF	ON	Curve 12 (TBA)
OFF	OFF	ON	ON	Curve 13 (TBA)
ON	OFF	ON	ON	Curve 14 (TBA)
OFF	ON	ON	ON	Curve 15 (TBA)
ON	ON	ON	ON	Curve 16 (TBA)

* indicates gases not performance certified

If the sensor's configuration setting (curve) is setup correctly as desired, **refer to Millennium II Basic Transmitter calibration procedure below and/or Figure 4 before attempting calibration.**

Millennium II Basic Transmitter Normal Calibration Procedure:

Calibrations may be performed either by using the magnet (non – intrusive) or by using the push button (intrusive).

1. Confirm successful power up of transmitter, (green blip/blink of status LED every second: no fault indicated).
2. Bypass any output alarms (recommended).
3. For analog model connect a standard current meter to the transmitter’s Test Jacks (not required but gives visual confirmation).
4. Press and hold the “**push button**” (or activate the “**Reed switch**” using the magnet) for at least 15 seconds, the status LED flashes green fast, and then goes solid green (first solid green). Keep holding “**push button**” or magnet, after which, status LED goes solid red. When this occurs, release “**push button**” or remove magnet.
5. When the current output is 3 mA (indicated by analog models) and the Status LED is once again solid green (second solid green), apply zero gas (clean air). **Recommendation:** Flow ZERO AIR at a rate of 0.5 liter per minute or more to the sensor.
6. When the current output is 3.3 mA(indicated by analog models) and the Status LED is flashing red, apply specific calibration gas (50% of full span). **Recommendation:** Flow span gas at a rate of 0.5 liter per minute to the sensor for direct sensor calibrations. If sensor is remotely mounted and long tubing run is used, increase gas flow rate (e.g. 1.0 liter per minute) to ensure tubing length does not affect calibration results.
7. When the current output is 3.6 mA (indicated by analog models) and the Status LED is solid green, remove the gas.
8. Apply zero gas (clean air) again to purge the system.
9. After the sensor is purged of gas, the detector will return to normal operation.

Note: When calibrating with the **Millennium II Basic Transmitter always use 50% span gas (half the scale). Calibration gas can be air balanced or nitrogen balanced for IR sensors.** Calibration instructions are also accessed using the HART Communicator with the Analog/HART model transmitter. For HART Menu Structure/Tree, see Millennium II Basic Transmitter manual (MAN-0082).

Zero Calibration Option:

This option is useful if the sensor’s zero point has drifted as a result of a change in the ambient conditions. The “**Zero**” calibration option is selected if a sensor is only being zeroed (this not a complete calibration). It does not require the application of span gas, as only the sensor’s zero point is adjusted. Ensure that no contaminants are present, if the surrounding air is to be used for Zeroing. If Zero calibration is needed, at step 4 above, hold the push button or activate Reed switch (for 6-9 seconds) using the magnet, until the status LED goes solid green, and then release the switch. Zero calibration will begin immediately.

See Figure 4: Calibration Flow chart for Millennium II Basic Transmitter on next page for additional reference.

Figure 4: Calibration Flow chart for Millennium II Basic Transmitter

Calibration Procedure

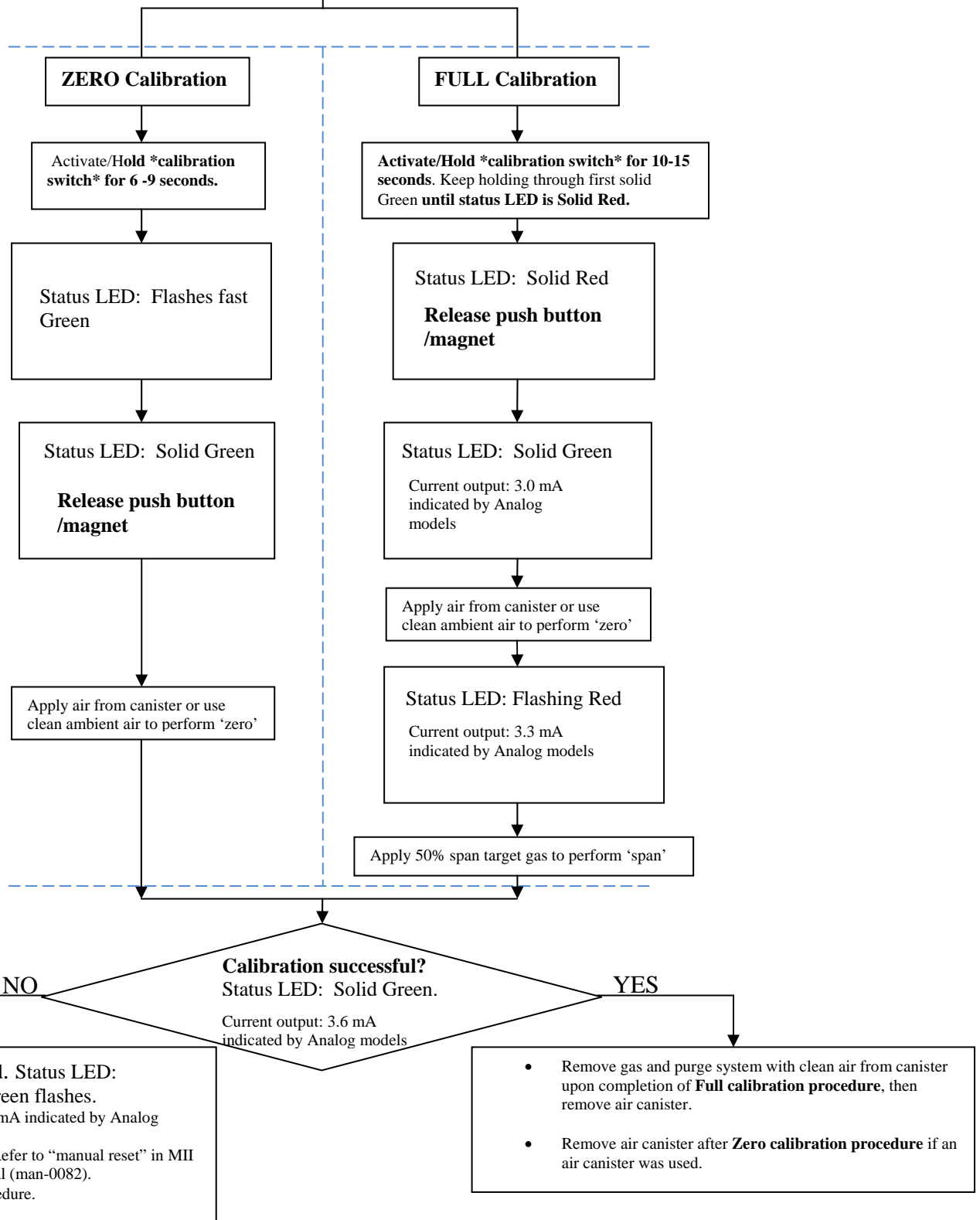

Note: * See the Millennium II Basic transmitter manual (MAN-0082) when locating calibration switch (push button) or magnetic switch.

5.1.2 Calibrating with the Millennium II Transmitter.

The Millennium II Transmitter allows monitoring and detection of various combustible gases. The following procedures are specific to this transmitter and should be followed to ensure accurate calibration and detection of gases. **Follow the steps below when selecting the particular gas to be detected (target gas).**

Selecting the target gas:

1. Enter the Main menu, first by pressing any key to get the “*enter main menu*” prompt, then press **menu button 1 (Reed switch 1)** to select “yes”.
2. Select the up arrow key (**menu button 1 or Reed switch 1**) or down arrow key (**menu button 2 or Reed switch 2**), until “*Select Gas Type*” option is displayed.
3. Select the enter key (**Menu button 3 or Reed switch 3**) to enter the option.
4. If channel 1’s gas type is to be configured, select with the enter key (**Menu button 3 or Reed switch 3** or ,
5. If channel 2’s gas type is to be configured, use the down arrow key (**Menu button 2 or Reed switch 2**) and then select with the enter key (**Menu button 3 or Reed switch 3**).
6. If the gas type displayed is not the required target gas, select the down arrow key (**Menu button 2 or Reed switch 2**) until the desired target gas is found.
7. Activate the enter key (**Menu button 3 or Reed switch 3**) to select the specific gas to be detected.
8. Use the down arrow key (**Menu button 2 or Reed switch 2**), then the enter key (**Menu button 3 or Reed switch 3**) until the main menu is completely exited.

Refer to Millennium II Transmitter calibration procedure below and/or Figure 5 before attempting calibration.

Millennium II Transmitter Normal (Full) Calibration Procedure:

If the sensor’s target gas is setup correctly as desired, follow the steps below for Full Calibration / Normal Calibration Procedure. **Always use 50% span gas (half the scale) of the specific target gas when calibrating this sensor.** Note that if a calibration is not successful the message “*Span failed*” will be displayed and a manual reset will have to be initiated. Refer to Millennium II Transmitter manual (MAN-0076) for manual reset.

1. Enter the main menu, first by pressing any key to get the “*enter main menu*” prompt, then press/select **menu button 1 or Reed switch 1** to select “yes”.
2. When “*Calibrate Sensor?*” is displayed, select the enter key (**menu button 3 or Reed switch 3**).
3. When “*Calibrate Sensor #1?*” is highlighted, press the enter key (**menu button 3 or Reed switch 3**) if this is the sensor to be calibrated or,
4. If Sensor #2 is to be calibrated, select the down arrow key (**menu button 2 or Reed switch 2**) to scroll to “*Calibrate Sensor #2?*”

5. When the desired sensor to be calibrated (1 or 2) is highlighted, activate the enter key (*menu button 3* or *Reed switch 3*).
6. Select “YES” (*menu button 1* or *Reed Switch 1*) to confirm the selection.
7. Apply clean air when “Apply Clean Air” is displayed, then select “Z & Span” using (*menu button 1* or *Reed Switch 1*) for normal calibration. “Setting zero” will be displayed as the sensor is being zeroed. (Ensure no contaminant gases are around if ambient air is being used).
8. Apply 50% calibration gas when prompted. **Recommendation:** Flow span gas at a rate of 0.5 liter per minute to the sensor for direct calibrations. If sensor is remotely mounted and long tubing run is used, increase gas flow rate (e.g. 1.0 liter per minute) to ensure tubing length does not affect calibration results.
9. The display will show “Spanning” with the gas value (%LEL) as the gas is detected.
10. Remove the calibration gas when “Remove Cal Gas” is displayed.
11. “Cal Complete” will be displayed when calibration is complete.
12. Apply zero gas (clean air) to purge system.

Note: Calibration gas can be air or nitrogen balanced. Calibration instructions are also accessed using the HART Communicator with the single channel Millennium II Transmitter model.

Zero Calibration Option:

This option is useful if the sensor’s zero point has drifted as a result of a change in the ambient conditions. The “Zero” calibration option is selected if the sensor is only being zeroed (this not a complete calibration). The application of span gas is not required, as only the sensor’s zero point is adjusted. Ensure that no contaminants are present, if the surrounding air is to be used for Zeroing. If Zero calibration is needed, at step 7 above, select ‘Zero’ using (*menu button 3* or *Reed Switch 3*).

See Figure 5: Calibration Flow chart for Millennium II Transmitter on next page for additional reference. The chart shows calibration steps for channel 1. Calibration steps for channel 2 are similar.

Figure 5: Calibration Flow chart for Millennium II Transmitter

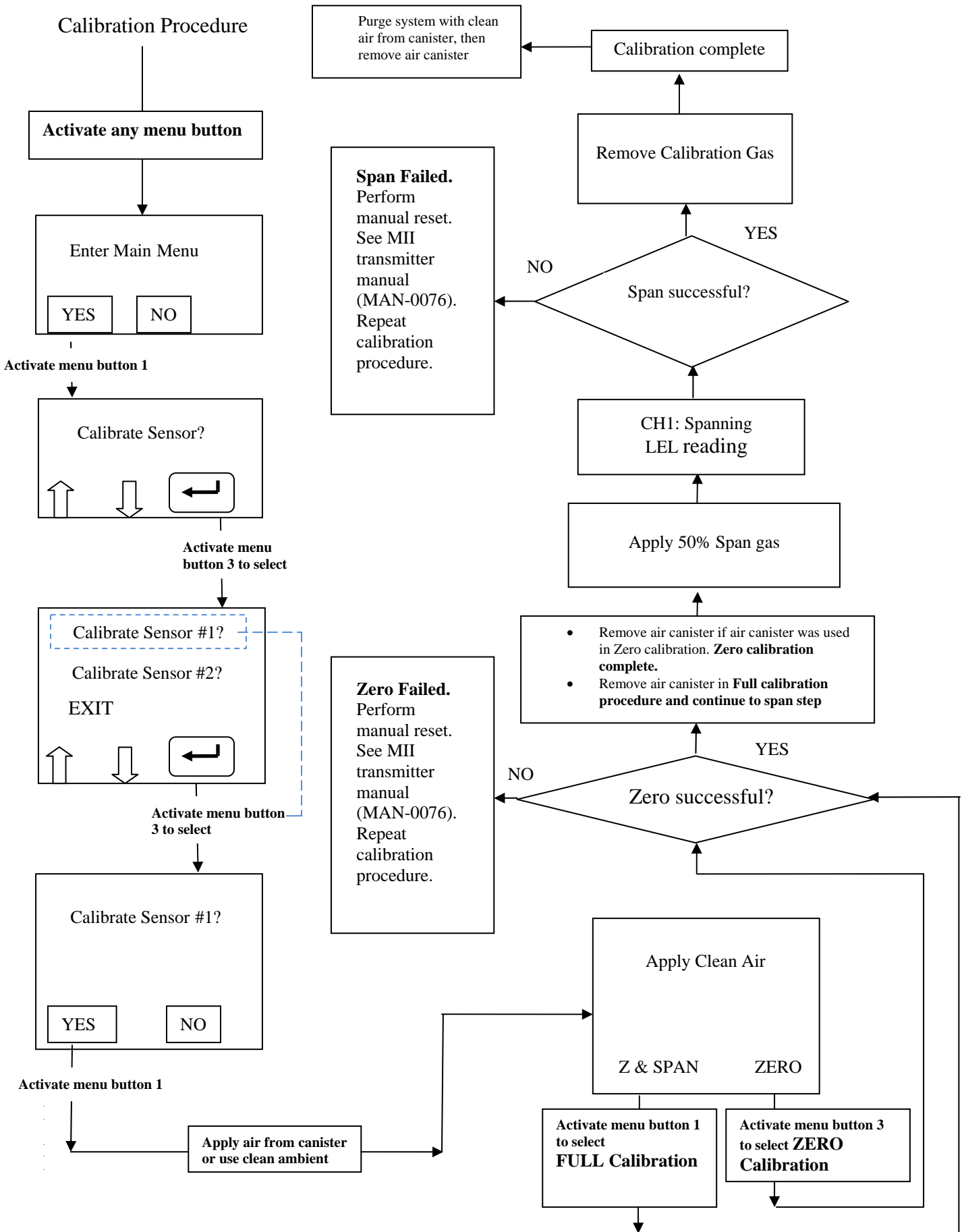

5.1.3 Cross sensitivity

This relates to the fact that certain compounds and or gases can cause a reaction and hence some effects or response from the sensor. This type of sensor will react to most compounds containing a Carbon-Hydrogen bond (hydrocarbons) in varying degrees. For more information, please contact the manufacturer.

5.2 Sensor Replacement Procedure

Sensors are pre-calibrated at the factory but field calibration must be performed as part of commissioning. When a calibration can no longer be performed or the sensor is not operating properly the sensor module may need to be replaced. Refer to steps below for replacing sensor module.

Warning  Do not open enclosure in a classified area.

Note: Components are ESD sensitive, as a result all ESD rules and procedures should be observed. See [Appendix A](#) for ESD guidelines.

To replace the sensor module:

1. Remove power from sensor.
2. Remove the locking ring by loosening the set screws with 1.5 mm Allen Key tool.
3. Remove the bottom part of the sensor enclosure by turning in a counter clockwise direction to expose sensor module.
4. Carefully remove sensor module from sensor enclosure.
5. Align and properly fit replacement sensor module.
6. Install and hand- tighten the bottom part of the sensor enclosure by turning in a clockwise direction.
7. Install the locking ring by tightening the set screws with 1.5 mm Allen Key tool.
8. Restore power to sensor via transmitter.

5.3 Troubleshooting

Sensors and controllers / transmitters are not designed to be repaired in the field. If problems should develop, first check for faulty wiring, confirm proper voltage to sensor, and attempt a calibration. If problems persist, please contact Net Safety's Service Department first by phone to try and resolve any issues. If issues cannot be resolved, please follow the procedure on next page, on 'how to return equipment.'

5.4 Storage

The sensor and its electronic components/parts should be stored in locations free from dust and moisture. The storage temperature should be well within the limits of the certified temperatures of the equipment. See Appendix C for certified temperatures.

5.5 Spare Parts / Accessories

Table 7: Available Spare Parts

Description	Net Safety Part Number
Calibration Cup / Splash Guard	CCS-1
Separation Kit	JB-MPD-A (aluminum) or JB-MPD-S (316 stainless steel)
Dust Filter Assembly	DSC-1
Replacement Mini IR Sensor	SC311-100
IP66/67 Hydrophobic Filter	IPF-001

5.6 How to Return Equipment

A Material Return Authorization number is required in order to return equipment. Please contact Net Safety Monitoring at **(403) 219-0688**, before returning equipment or consult our Service Department to possibly avoid returning equipment.

If you are required to return equipment, include the following information:

1. A Material Return Authorization number (provided over the phone to you by Net Safety).
2. A detailed description of the problem. The more specific you are regarding the problem, the quicker our Service Department can determine and correct the problem.
3. A company name, contact name and telephone number.
4. A purchase order, from your company, authorizing repairs or request for quote.
5. Ship all equipment, prepaid to:
**Net Safety Monitoring Inc.,
2721 Hopewell Place NE,
Calgary, Alberta, Canada, T1Y 7J7**
6. Mark all packages: **RETURN for REPAIR.**
7. Waybills, for shipment outside Canada, must state: **Equipment being returned for repair
All charges to be billed to the sender**

Ensure a duplicate copy of the packing slip is enclosed inside the box indicating item 1 – 4 along with the courier and account number for returning the goods.

Pack items to protect them from damage and use anti-static bags or aluminum-backed cardboard as protection from electro-static discharge.

ALL equipment must be shipped prepaid. Collect shipments will not be accepted.

Appendix

Appendix A: Electrostatic Sensitive Device (ESD)

Definition: Electrostatic discharge (ESD) is the transfer, between bodies, of an electrostatic charge caused by direct contact or induced by an electrostatic field.

The most common cause of ESD is physical contact. Touching an object can cause a discharge of electrostatic energy—**ESD!** If the charge is sufficient and occurs near electronic components, it can damage or destroy those components. In some cases, damage is instantaneous and an immediate malfunction occurs. However, symptoms are not always immediate—performance may be marginal or seemingly normal for an indefinite period of time, followed by a sudden failure.

To eliminate potential ESD damage, review the following guidelines:

- Handle boards by metal shields—taking care not to touch electronic components.
- Wear grounded wrist or foot straps, ESD shoes or heel grounders to dissipate unwanted static energy.
- Prior to handling boards, dispel any charge in your body or equipment.
- Ensure all components are transported and stored in static safe packaging
- When returning boards, carefully package in the original carton and static protective wrapping
- Ensure **ALL** personnel are educated and trained in ESD Control Procedures

In general, exercise accepted and proven precautions normally observed when handling electrostatic sensitive devices. A warning label is placed on the packaging, identifying product using electrostatic sensitive semiconductor devices.





Appendix B: Resistance Table

Distance (Feet)	AWG #20 0.5mm ²	AWG #18 0.8mm ²	AWG #16 1.0mm ²	AWG #14 2.0mm ²
100	1.02	0.64	0.40	0.25
200	2.03	1.28	0.80	0.51
300	3.05	1.92	1.20	0.76
400	4.06	2.55	1.61	1.01
500	5.08	3.20	2.01	1.26
600	6.09	3.83	2.41	1.52
700	7.11	4.47	2.81	1.77
800	8.12	5.11	3.21	2.02
900	9.14	5.75	3.61	2.27
1000	10.20	6.39	4.02	2.53
1250	12.70	7.99	5.03	3.16
1500	15.20	9.58	6.02	3.79
1750	17.80	11.20	7.03	4.42
2000	20.30	12.80	8.03	5.05
2250	22.80	14.40	9.03	5.68
2500	25.40	16.00	10.00	6.31
3000	30.50	19.20	12.00	7.58
3500	35.50	22.40	14.10	8.84
4000	40.60	25.50	16.10	10.00
4500	45.70	28.70	18.10	11.40
5000	50.10	32.00	20.10	12.60
5500	55.80	35.10	22.10	13.91
6000	61.00	38.30	24.10	15.20
6500	66.00	41.50	26.10	16.40
7000	71.10	44.70	28.10	17.70
7500	76.10	47.90	30.10	19.00
8000	81.20	51.10	23.10	20.20
9000	91.40	57.50	36.10	22.70
10000	102.00	63.90	40.20	25.30

Resistance shown is one way. This figure should be doubled when determining closed loop resistance.

Appendix C: Millennium II Mini IR Combustible Sensor Specifications

SENSOR	Mini IR combustible
Performance	
Response Time	T50 ≤ 4.3 sec T60 ≤ 7.0 sec T90 ≤ 11.0 sec
Accuracy	(+/-) 2% full Scale < 50% Full Scale (+/-) 5% Full Scale > 50% Full Scale
Zero Drift	N/A
Repeatability	+/- 2% LEL Full Scale
Environmental	
Temperature	Performance verified: -55°C to +85°C Certified: -40°C to +75°C
RH	0 – 99% RH non condensing
Metallurgy	Aluminum (AL6061) or Stainless Steel (316 SS)
IP / Nema Rating	IP64 / NEMA 4X
Weight	Aluminum (AL6061) enclosure: 0.4kg/1.0lbs, Stainless Steel (SS316) enclosure: 1.4kg/3.5lbs
Separation	
Separation	Up to 2000 feet / 600 meters with 16 AWG wire
Approvals	
Approvals	 Class I, Div1, Grps BCD; Class I, Zone 1, AEx/Ex d IIB+H2, T5, IP64, Type 4X, -40°C < Ta < +75°C. FM6320, CSA-C22.2 No 152, EN61779-4 FM ATEX CE 0575  II 2G, Ex d IIB+H2, T5, IP64 FM07ATEX0012X.

Net Safety Monitoring Inc.
2721 Hopewell Place NE, Calgary, AB Canada T1Y 7J7
1-866-FIREGAS (347-3427) | ph. (403) 219-0688 | fx. (403) 219-0694
<http://www.net-safety.com> | Email: nsmsales@net-safety.com

PRODUCT SERVICES CONTACT INFORMATION
Telephone [8am - 5pm MDT]: (403) 769-6074 | (403) 717-8219
Fax: (403) 219-0694 Email: productservices@net-safety.com
http://www.net-safety.com/service/product_services.html



MAN-0091 Rev 3 IR Combustible Sensor
August 27, 2010
Net Safety Monitoring Inc.