



MILLENNIUM II BASIC



ISO 9001:2000



: MAN-0082 . 1
2008 .

Monitoring Inc.

Net Safety

Monitoring Inc.

, Net Safety Monitoring Inc.

Net Safety

Net Safety Monitoring Inc.

Net Safety Monitoring Inc.

36

, Net Safety Monitoring Inc.
Net Safety Monitoring Inc.

Net Safety Monitoring Inc.

www.net-safety.com

Net Safety Monitoring Incorporated
Corporate Headquarters
2721 Hopewell Place NE
Calgary, AB Canada T1Y 7J7

: (403) 219-0688
: (403) 219-0694
E-mail: info@net-safety.com
- : www.net-safety.com

	4
	2
	2
	5
	5
	5
	5
	6
1.	7
1.1	7
1.2	7
2.	7
2.1	7
	7
2.1.1	8
	8
2.2	9
2.2.1	(/HART).....	9
2.2.2	11
2.2.3	11
2.2.4	/.....	12
3.	13
3.1	/ HART-.....	13
3.2	HART-.....	14
3.3	/.....	15
3.4	/.....	16
4.	17
4.1	DIP-.....	17
4.1.1	DIP-.....	17

4.1.2	DIP-	Modbus	18
	DIP-	Modbus ()	19
4.1.3	DIP-	/ HART	19
5.			20
5.1			20
5.1.1			20
5.1.2		/	20
5.1.3		()	21
5.1.4			22
5.1.5			22
6.			23
6.1			23
6.2			23
6.2.1	4-20		23
6.2.2			23
6.2.3		, LED	24
6.2.4	Modbus/		26
6.2.5	HART		26
6.2.6	HART		26
7.			27
7.1			27
7.2			27
7.3	/		27
7.4			28
			29
A:		(ESD)	29
B:			30
:		Millennium II Basic	31
D:		HART	32
:		HART	34
:()	35

Millennium II,

Millennium II Basic,

« »

Millennium II Basic –

Millennium II (/HART, SX3)

()

« »

Millennium II Basic,

(AL)

1: Millennium II Basic () ()

Millennium II Basic	A		B		C		D		E		F		G	
(AL)	4,8	122	3,6	91	3,6	91	4,8	122	5,1	130	0,3	7,6	3,0	76
()	4,7	119	3,6	,1	3,6	,1	4,7	119	5,1	130	0,3	7,6	3,2	81

1:

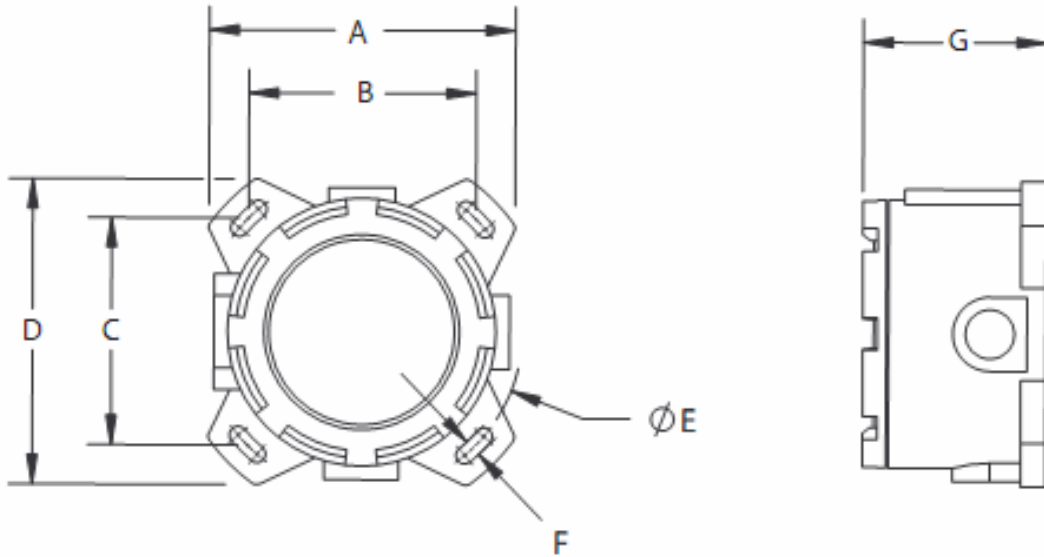

1.

1.1

Net Safety Monitoring.

1.2

2.

2.1



5°C

. ATEX

85°C.



).

(

•

•

4 – 20 A

,

4 – 20 A

•

•

•

•

MIL-W16878D

« ».

IEC 61000-1, IEC 61000-4 EMI
B/N.

•

•

•

•

:

/HART,

2.1.1



,

/

-55°C +85 °C.

Millennium II,

:

•

« »,

..

« ».

•

•

L-1

+½ +1½.

2.2



2

2:

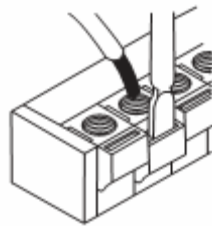

(ESD).

2.2.1

/HART)

(

()

3, 4 5.

3:

()

2 3

()

1 2

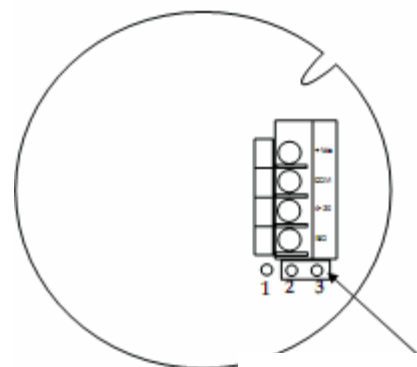

4: /HART-) (

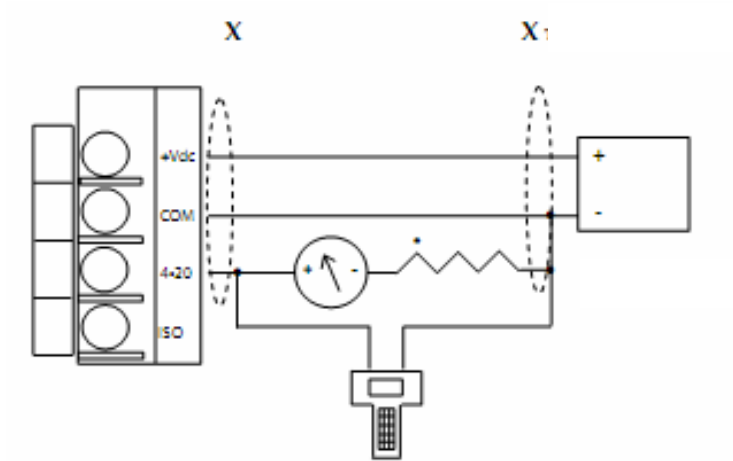

5: /HART-) (

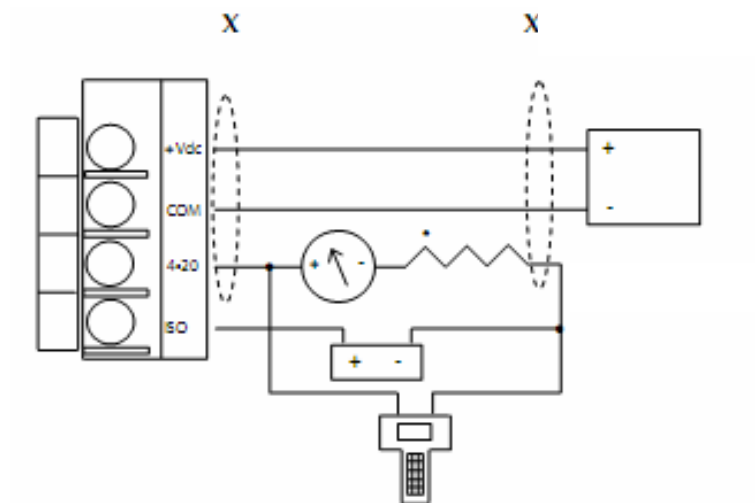

2.2.2

(MAN-0081).

2.2.3

LED , . LED

3,0 A,

« »

LED

«

, LED

»

2.2.4

/

3 (S2)

15



Calibration / Reset (/ « »):

6.

6:

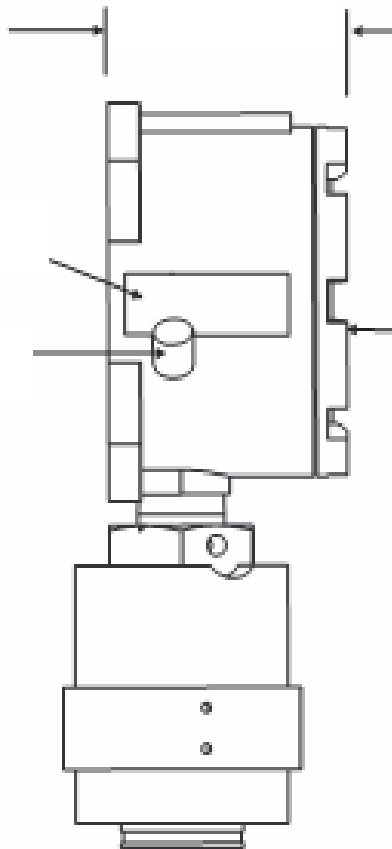

3:

3.1

/

HART-

2.

		+Vdc	SigA	SigB	COM	Shld
		10,5-32				
		+Vdc	COM	4-20	ISO	
		10,5-32 (+)	(-)			

7:

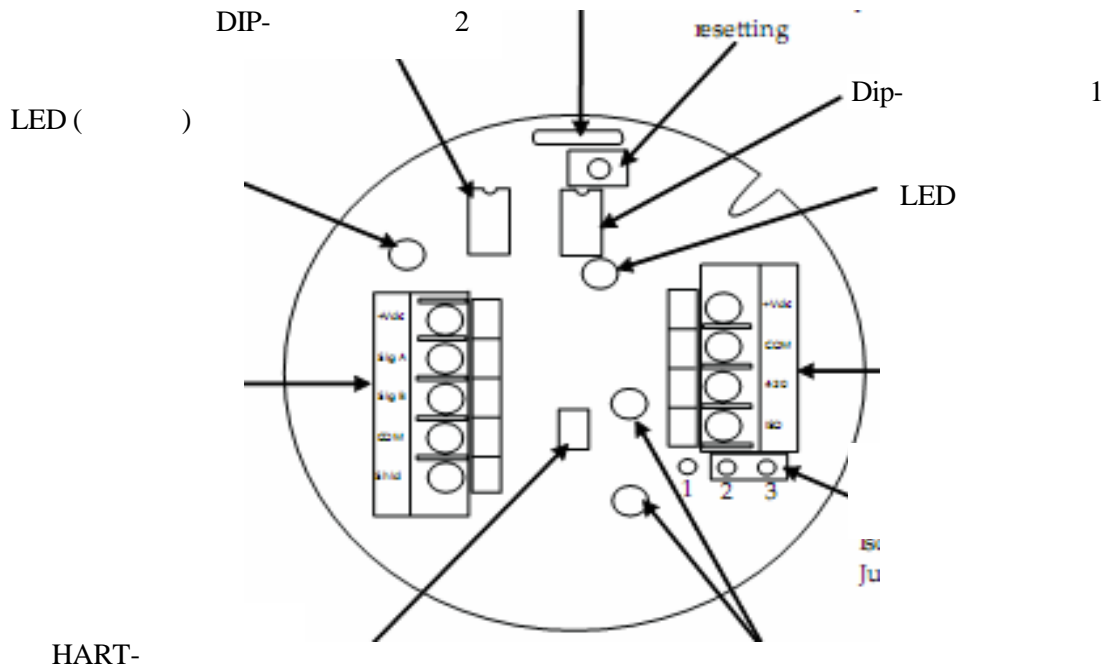

3.2

HART-

Millennium II Basic
HART-
HART-

/

HART-

HART-

Net Safety.

HART-

/

Man- 0083 MAN-0081.

HART-

:

HART-

250 600 .

Millennium II Basic.

3.3 /

1 () 2 (;)

3.

				+Vdc		SigA		SigB		COM		Shld	
				10,5-32									
		RST	+Vdc	COM	FNO	FCOM	FNC	A1NO	A1COM	A1NC	A2NO	A2COM	A2NC
			(+)10,5-32	(-)				1			2		

8:

Dip- 3 -

Dip- (.3.1)

LED ()

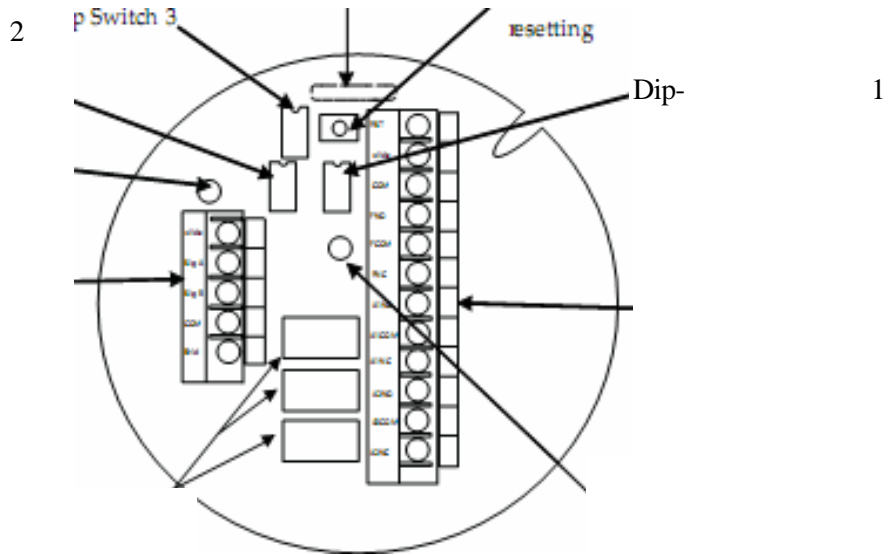

3.4 /

4.

				+Vdc	SigA	SigB	COM Shld
				10,5-32			
		+Vdc	COM	A		COM	Shld
		(+)10,5-32	(-)	Modbus RTU A	Modbus RTU	Modbus RTU	

9 -

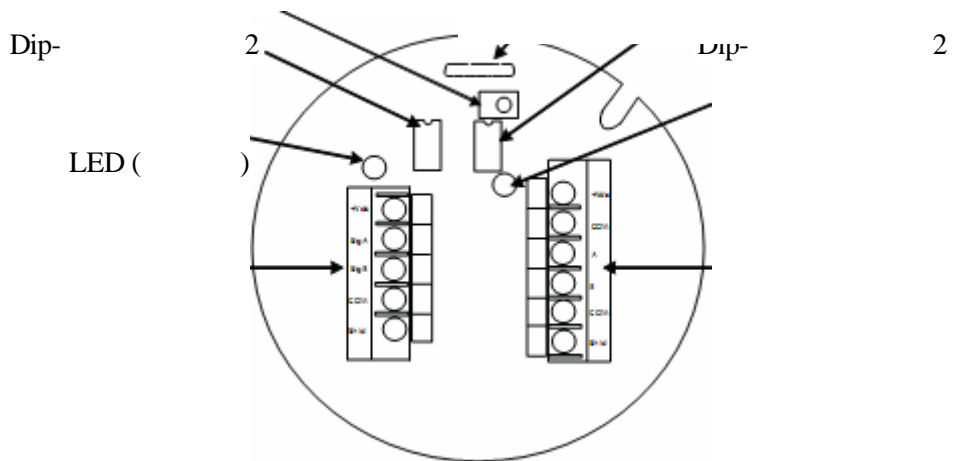

4.

4.1

DIP-

DIP-

1 3

. DIP-

1 2

Modbus

,
DIP-

2

/

- HART

1,

(DIP-

2),

DIP-

4.1.1

Dip-

Dip-

DIP-

1 3,

3

4

DIP-

1,

:

(10% / 50),

50, DIP-
5,

1,

2 4
10.

' (8%+2%),

Dip- 1				
1	.	16%	DIP- 3, 4 (%)	
	.	0%		
2	.	8%		
	.	0%		
3	.	4%		
	.	0%		
4	.	2%		
	.	0%		
Dip- 3				
1	.			Dip- 1 (% /)
	.			
2	.			
	.()			
3	.			
	.()			
* 4*	.	32%		
	.	0%		

LED

4.1.2

DIP-

Modbus

Dip- 1 MODBUS. Dip- 2 MODBUS. MODBUS. 3 4
 Dip- 1 2 Dip- 2 MODBUS
 Dip- 2 MODBUS.
 Dip- ML2 Basic.

Dip- 1 Modbus:

1	2	3	4	MODBUS
.	.	.	.	16
.	.	.	.	15
.	.	.	.	14
.	.	.	.	13
.	.	.	.	12
.	.	.	.	11
.	.	.	.	10
.	.	.	.	9
.	.	.	.	8
.	.	.	.	7
.	.	.	.	6
.	.	.	.	5
.	.	.	.	4
.	.	.	.	3
.	.	.	.	2
.	.	.	.	1

DIP- Modbus ()
 Dip- 2 :

1	2	
.	.	19200
.	.	9600
.	.	4800
.	.	2400

Dip- 2 :

1	2	
.	.	8- , ,2 (1)
.	.	8- , ,2
.	.	8- , ,1
.	.	8- , ,1

4.1.3 DIP- / HART
 Dip- 2 / Dip- 2 1
 . . . / Dip- 2 1
 « () » « », – « ».

5.

5.1

50%

Millennium II Basic

5.1.1

Millennium II Basic

2

Millennium II Basic

24-

5.1.2

/

1. , : (/ LED
2. () .
3. (,)
4. « » (15 , LED () , « » , « ») .
5. 3 A () , LED () .
6. : 0,5
7. 3,3 A () , LED (50%) .
8. : 0,5
9. 3,6 A () , LED
10. ()
11. ,

: . 5.

5.

	4 A		4 A	3 A	3,3 A	3,6 A	4 A
	.		10-15 (,)	()	(50%)		
LED	/						/

5.1.3

()

:

1. , () / LED
2. () .
3. (,) .
4. « LED » () ,
5. LED , 3 A () , (0,5) . :
6. () , LED 3,6 A (/) . (4) .
7.) / 4 () .

:

6.

6.

	4 A	4		3 A	3,6 A	3,0 A
			6-9	()		
LED	/					/



5.1.4

LED

3,0 3,3 A

5.1.5

« » (S2) 3 ,

» (*Calibration / Reset* (/))

, 3 . LED

6.

6.1

LED

2,5



6.2

Millennium II Basic

, RS-485 Modbus RTU

, HART.

4-20 A,

6.2.1

4-20

- 20 A.

4,0 A

4,0 A

; 4,0 – 20,0 A

4

6.2.2

5 30 /250

3

.2

«

»

«

»

«

»

«

».

«

/

».

6.2.3

, LED

7

LED

7:

	(A)	LED		
		()	()	
0	4-20	()	()	-
1	3.0		()	
2	3.3			,
3	3.3			,
4	3.6			,
5	3.6			4 3%
6	2.5			,
7	3.0			90 ()
8	3.6			4,
9	3.0/3.3			90
10	3.0/3.3			4 , 90-
11	2.5			: (-40°C).
12	2.5			: (+75°C).
13	2.5			: <8 .
14	2.5			: >33 .

	(A)	LED		
15	2.5			
16	20.0			,
17	2.5			» () « :
18	2.5			:
20	2.5			:
21	2.5			:

6.2.4 Modbus /

RS-485 Modbus RTU.

Modbus

6.2.5 HART

HART –

Millennium II Basic.

HART-

Millennium

II Basic

Millennium II Basic

Millennium II Basic.

Millennium II Basic

D

6.2.6

HART

HART-

HART,

7.

7.1

Net Safety Monitoring

3

LED

Millennium II Basic

50% , 11,5 A (47%) 12,5
 A (53%).
 10% , 10,7 A (42%) 13,3 A (58%)
).

7.2

Millennium II Basic.

Millennium II Basic

7.3

8.

Net Safety	
CCS-1	/
JB-MPNS-A (), JB-MPNS-S ()	JB-MPNS-A JB-MPNS-S
DSC-1	
TX-M2B-AH	Hart ML2B
TX-M2B-A	ML2B
TX-M2B-D	Modbus ML2B
TX-M2B-R	ML2B

7.4

Authorization number). (Material Return
Net Safety Monitoring
(403) 219-0688 , - ,

- 1. (Net Safety).
- 2. ,
- 3. ,
- 4. - ,
- 5. : Net Safety Monitoring Inc., 2721 Hopewell Place NE,
Calgary, Alberta, Canada, T1Y 7J7
- 6. : RETURN for REPAIR ().
- 7. : Equipment being returned
for repair All charges to be billed to the sender (,)

1-4,

A:

(ESD)

:

!

-
-
-
-
-
-





B.

1

()	AWG #20	AWG#18	AWG#16	AWG#14	AWG#12	AWG#10	AWG#8
30.5	1.02	0.64	0.40	0.25	0.16	0.10	0.06
61	2.03	1.28	0.80	0.51	0.32	0.20	0.13
91.5	3.05	1.92	1.20	0.76	0.48	0.30	0.19
122	4.06	2.55	1.61	1.01	0.64	0.40	0.25
152.5	5.08	3.20	2.01	1.26	0.79	0.50	0.31
183	6.09	3.83	2.41	1.52	0.95	0.60	0.38
213.5	7.11	4.47	2.81	1.77	1.11	0.70	0.44
244	8.12	5.11	3.21	2.02	1.27	0.80	0.50
274.5	9.14	5.75	3.61	2.27	1.43	0.90	0.57
305	10.20	6.39	4.02	2.53	1.59	1.09	0.63
381	12.70	7.99	5.03	3.16	1.99	1.25	0.79
457.5	15.20	9.58	6.02	3.79	2.38	1.50	0.94
534	17.80	11.20	7.03	4.42	2.78	1.75	1.10
610	20.30	12.80	8.03	5.05	3.18	2.00	1.26
686	22.80	14.40	9.03	5.68	3.57	2.25	1.41
762.5	25.40	16.00	10.00	6.31	3.97	2.50	1.57
915	30.50	19.20	12.00	7.58	4.76	3.00	1.88
1067.5	35.50	22.40	14.10	8.84	5.56	3.50	2.21
1220	40.60	25.50	16.10	10.00	6.35	4.00	2.51
1372.5	45.70	28.70	18.10	11.40	7.15	4.50	2.82
1525	50.10	32.00	20.10	12.60	7.94	5.00	3.14
1677.5	55.80	35.10	22.10	13.91	8.73	5.50	3.46
1830	61.00	38.30	24.10	15.20	9.53	6.00	3.77
1982.5	66.00	41.50	26.10	16.40	10.30	6.50	4.08
2135	71.10	44.70	28.10	17.70	11.10	7.00	4.40
2287.5	76.10	47.90	30.10	19.00	12.00	7.49	4.71
2440	81.20	51.10	33.10	20.20	12.70	7.99	5.03
2745	91.40	57.50	36.10	22.70	14.30	8.99	5.65
3050	102.00	63.90	40.20	25.30	15.90	9.99	6.28

1

C: Millennium II Basic

			/HART	
(<200 A 24			
)	10,5 - 32	10,5 - 32	18 - 32	10,5 - 32
-	: 150 170		450 470 ,5 FM	1 ;
			: IEC 61000-1-4 IEC 61000-4-3	2
	LED (,)			
	: -55°C +85°C			
	0 - 99%			
	, , 316			
IP/NEMA	IP67/Nema4X			
	/ 2			
	(3)5A 30	4-20	4-20 HART-	RS 485 Modbus RTU
	(,)			
	 Class 1, Div 1, Grps BCD; Class I, Zone 1 AEx/Ex d IIB+H2, T5, IP67, Type 4X, -55°C +85°C FM ATEX:  0575  II 2G, Ex d II + 2, T5, IP67, -55°C +85°C. FM07 ATEX 0013X FM 6320, CSA-C22.2 No. 152, ISA-92.0.01, EN61779-4			

D: HART

HART Millennium II Basic

HART

Millennium II Basic

HART.

HART Millennium II Basic

1. HART- Millennium II Basic.
2. HART- ().
3. «on» (« .») HART.
4. «HART Application» (« HART») ,
Millennium II Basic.
«Online», Millennium II Basic.

HART- « » (DDL),
HART-

, DDL.

Millennium II Basic, HART- ,

16- 2.0. 16- 375

:

- HART-

HART.

- HART-

16- , Millennium II Basic

HART-
HART- Millennium II Basic

Millennium II Basic. HART-

DDL Millennium II Basic

Millennium II Basic DDL

1. HART Application (HART).
2. HART Offline.
3. Offline New Configurations () HART. DDL.
4. Manufacturer () Net-Safety, Millennium II Basic Net-Safety DDL. HART- DDL. HART- (www.hartcomm.org) HCF. DDL, HCF.

Millennium II Basic HART

Millennium II Basic.
HART 6

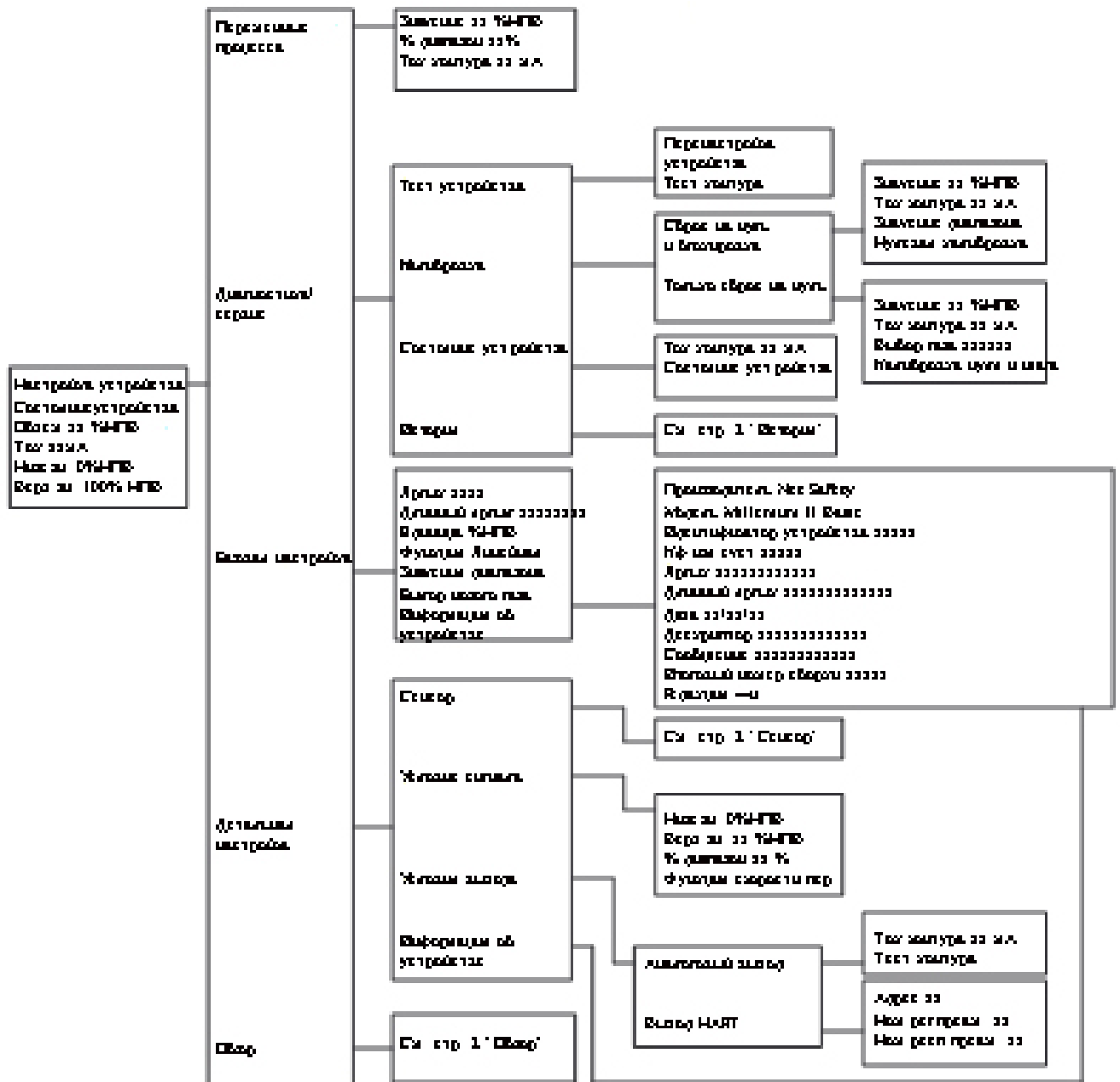

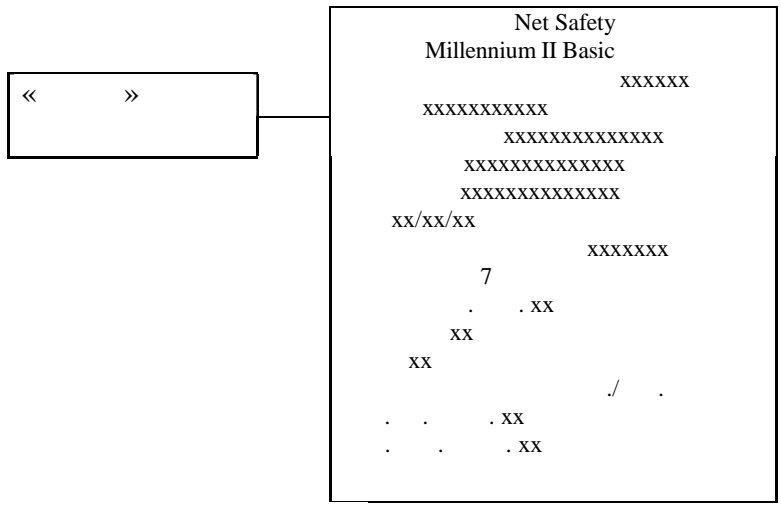
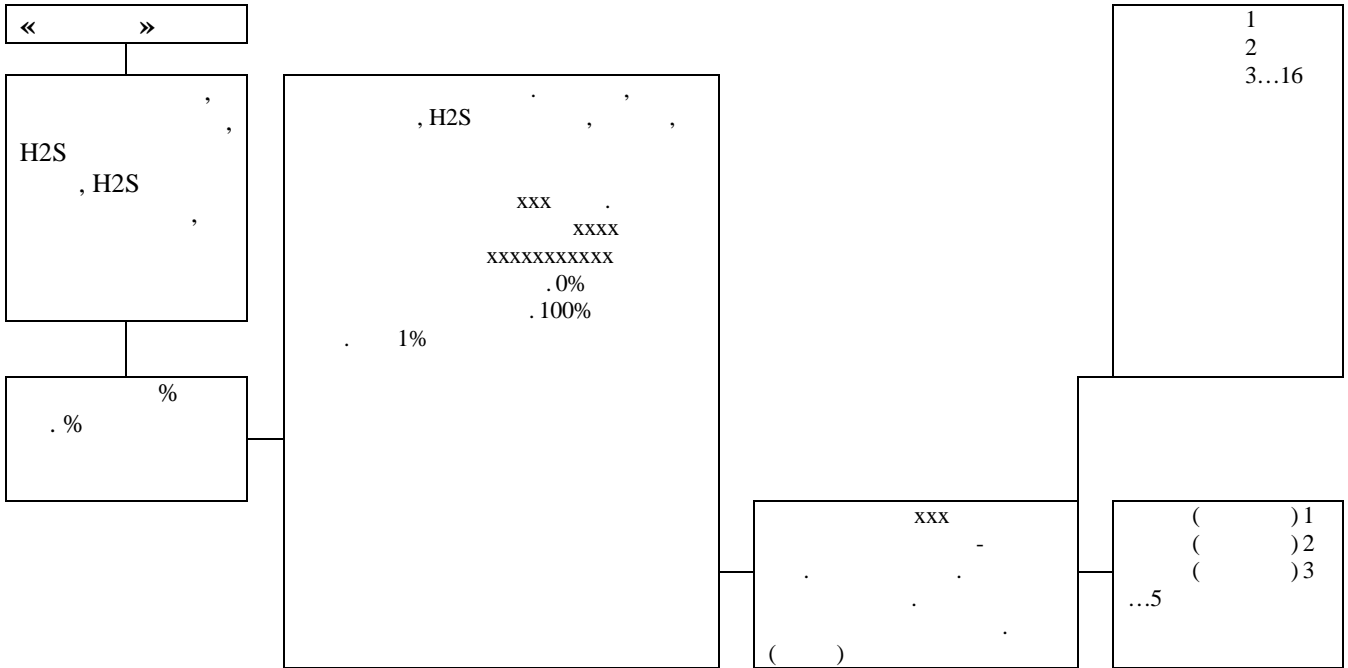
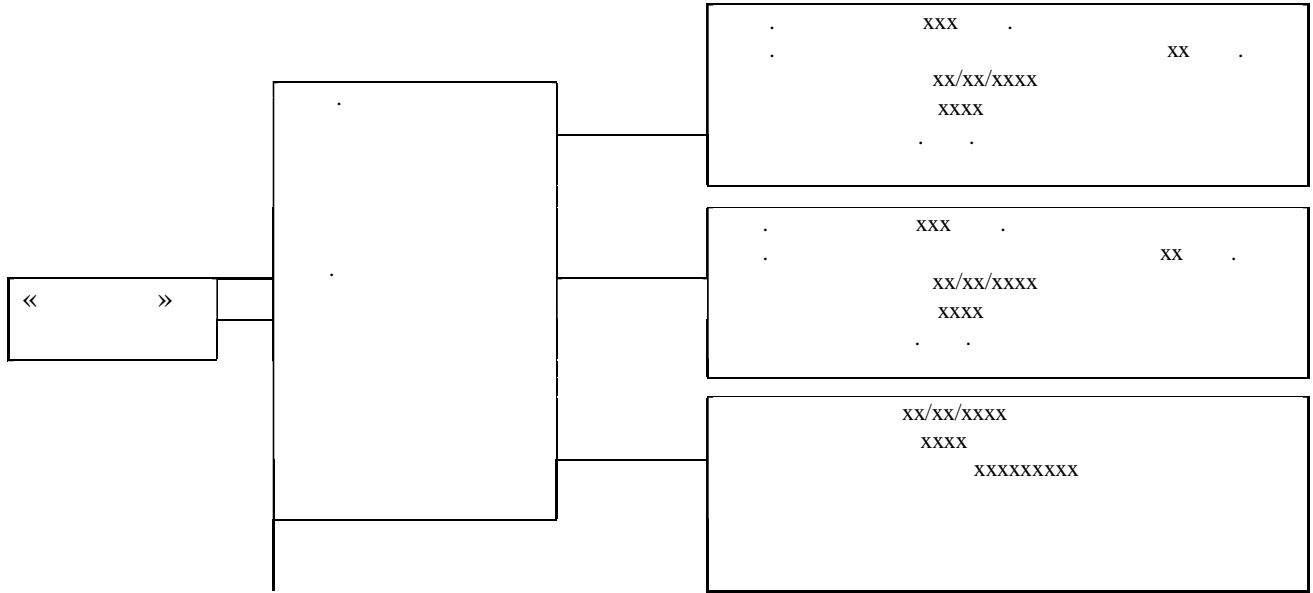

Net Safety Monitoring Inc.
2721 Hopewell Place NE, Calgary, AB Canada T1Y 7J7
1-866-FIREGAS (347-3427). (403) 219-0688. (403) 219-0694
<http://www.net-safety.com> info@net-safety.com

[8:00 – 17:00]: (403) 769-6074; (403) 717-8219.
: (403) 219-0694 Email: productservices@net-safety.com
http://www.net-safety.com/service/product_services.html

