



## **MILLENNIUM Infrared Combustible Gas Detector**

**User Manual**

**Models:**

**MLP-A-SIR100, MLP-AR-SIR100**

**MLP-AD-SIR100**

**&**

**(all available options)**



ISO 9001:2000



Part Number: MAN-0059 Rev 07  
July 2008

## **IMPORTANT INFORMATION**

This manual is for informational purposes only. Although every effort has been made to ensure the correctness of the information, technical inaccuracies may occur and periodic changes may be made without notice. Net Safety Monitoring Inc., assumes no responsibility for any errors contained within this manual.

If the products or procedures are used for purposes other than as described in the manual, without receiving prior confirmation of validity or suitability, Net Safety Monitoring Inc., does not guarantee the results and assumes no obligation or liability.

No part of this manual may be copied, disseminated or distributed without the express written consent of Net Safety Monitoring Inc.

Net Safety Monitoring Inc., products are carefully designed and manufactured from high quality components and can be expected to provide many years of trouble free service. Each product is thoroughly tested, inspected and calibrated prior to shipment. Failures can occur which are beyond the control of the manufacturer. Failures can be minimized by adhering to the operating and maintenance instructions herein. Where the absolute greatest of reliability is required, redundancy should be designed into the system.

## **Warranty**

Net Safety Monitoring Inc., warrants its sensors against defective parts and workmanship for a period of 24 months from date of purchase; other electronic assemblies for 36 months from date of purchase.

No other warranties or liability, expressed or implied, will be honoured by Net Safety Monitoring Inc.

Contact Net Safety Monitoring Inc., or an authorized representative for details.

We welcome your input at Net Safety Monitoring. If you have any comments please contact us at the phone/address below or visit our web site and complete our on-line customer survey: [www.net-safety.com](http://www.net-safety.com).

## **Contact Information**

Net Safety Monitoring Inc.  
2721 Hopewell Place NE  
Calgary, AB  
Canada  
T1Y 7J7  
Telephone: (403) 219-0688 Fax: (403) 219-0694  
[www.net-safety.com](http://www.net-safety.com)  
E-mail: [netsafe@net-safety.com](mailto:netsafe@net-safety.com)

Copyright © 2005  
Net Safety Monitoring Inc.  
Printed in Canada

---

# TABLE OF CONTENTS

## Important Information

- Warranty
- Contact Information

<b>Introduction</b> .....	<b>1</b>
The Product .....	1
The Sensor .....	1
The Controller .....	1
The Manual .....	1
<b>Step 1 — Plan</b> .....	<b>2</b>
Locate Controller/Sensor .....	2
Figure 1: Locate Sensor/Controller .....	2
Figure 2: Dimensional Drawings .....	3
<b>Step 2 — Install</b> .....	<b>3</b>
Unpack .....	3
Figure 3: Components .....	3
External Equipment .....	3
Mount .....	4
<b>Step 3 — Wire</b> .....	<b>4</b>
Field Installation .....	4
Seal .....	4
Connecting Wires .....	4
Board Assembly .....	5
Figure 4: Millennium Modular Boards .....	5
Figure 5: Wiring—Controller and Sensor .....	6
Sensor and Controller .....	6
Table 1: Controller/Sensor Terminal Connections .....	6
RS-485 Communication .....	6
Sensor Separation .....	7
Figure 6: Wiring—Sensor Separation .....	7
Non-Isolated/Isolated Wiring .....	8
Terminal Connection .....	8
Figure 7: Non-isolated Terminal Connection .....	8
Figure 8: Isolated Terminal Connection .....	8
Current Output .....	8
Figure 9: Jumper Positions .....	8

Remote Reset .....	9
Figure 10: Remote Reset .....	9
MODBUS Termination .....	9
Figure 11: Modbus Termination Jumpers .....	9
<b>Step 4 — Operate</b> .....	<b>10</b>
Figure 12: Controller Functionality .....	10
Table 2: Status LEDs, Display Messages and Current Loop .....	11
RTU Registers .....	11
Table 3: RTU Status Register (400002) Read Only (binary) .....	11
Calibration Button .....	11
Magnetic Reed Switch .....	12
Power Up .....	12
Current Loop Measurement (Test Jacks) .....	12
Status LED .....	12
The Main Menu .....	12
Accessing the Main Menu .....	12
Main Menu Functionality .....	12
<b>Step 5 — Calibrate</b> .....	<b>13</b>
Calibration Procedure .....	13
Calibration Procedure .....	13
Figure 13: Calibration Procedure .....	13
Calibration Failure .....	14
<b>Step 6 — Monitor</b> .....	<b>14</b>
Review Relay Settings .....	14
Set Relay Options .....	14
Table 4: Default Relay Settings .....	14
Setting Relay Options .....	15
Select Gas Curve .....	15
Select Display Language .....	15
Modbus Options .....	16
Node Address .....	16
Baud Rate .....	16
Alarms .....	16
Sensor Fault .....	16
Gas Present .....	16
Sensor Life .....	16
Reset .....	17
Manual Reset .....	17
Remote Reset .....	17

---

Outputs .....	17
Relay .....	17
Modbus .....	17
Current .....	17
<b>Step 7 — Maintain .....</b>	<b>18</b>
Periodic Response Check .....	18
<b>Troubleshoot .....</b>	<b>18</b>
<b>How to Return Equipment .....</b>	<b>18</b>
Spare Parts/Accessories .....	19
Table 5: Part Numbering .....	19
Face Rotation Option .....	19
Figure 14: Non-standard Orientations .....	19
Rotate PCB Assembly .....	19
<b>Appendix A: Electrostatic Sensitive Device (ESD) .....</b>	<b>20</b>
<b>Appendix B: Resistance Table .....</b>	<b>21</b>
Table 6: Wire Resistance In Ohms .....	21
<b>Appendix C: Specifications .....</b>	<b>22</b>

---

## **INTRODUCTION**

The Millennium series is Net Safety's latest innovation in a line of continuously evolving industrial gas detectors and sensors. The microcontroller based system provides fast, accurate and continuous monitoring of gases in extreme environments.

## **THE PRODUCT**

### **The Sensor**

The SIR100 digital infrared sensor employs a simple and effective optical design. There are no mirrors to be fogged, fouled, misaligned or cleaned. The entire optical path is protected from airborne contaminants such as mist, dust and oil and de-fogging heaters are not required.

### **The Controller**

The Millennium Controller has an explosion-proof Housing, rated Class 1, Division 1, Groups B, C, and D for hazardous applications. It was designed for either a 1-man, intrusive calibration or 2-man non-intrusive calibration.

The Controller has convenient user interface functionality to make installation, operation and maintenance easy.

### **The Manual**

The manual has been designed to make installation of the Millennium product easy. To ensure proper installation, follow the steps outlined in the following pages. If you encounter problems during operation, consult the troubleshooting section or contact your sales representative.

**Step 1 — PLAN**

**Step 2 — INSTALL**

**Step 3 — WIRE**

**Step 4 — OPERATE**

**Step 5 — CALIBRATE**

**Step 6 — MONITOR**

**Step 7 — MAINTAIN**

## STEP 1 — PLAN

### LOCATE CONTROLLER/SENSOR

Prior to the installation process, a location plan for placing the Controller and Sensor should be developed. Although there are no absolute rules for determining the quantity and location of a sensor or controller, the following points should be considered when planning the installation.

- Locate the Controller where it will be accessible and visible.
- Carefully locate Sensor in an area where gases may potentially accumulate.
- Use redundant systems to enhance protection and reliability.
- Light gases tend to rise; heavy gases tend to accumulate in low areas.
- Consider air movement patterns within the facility.
- Consider the construction of the facility (such as trenches where heavy gases may accumulate or peaks where light gases may accumulate).
- Seek advice from experts knowledgeable about the primary gas to be detected.
- Use common sense and refer to various regulatory publications that discuss general guidelines for your industry.

The two most common installation options are as follows.

#### Option 1

Sensor is located lower to the ground to detect heavy gases

The Sensor is attached directly to the Controller. A Calibration Cover is slipped onto the bottom of the Sensor and the calibration gas is attached to the side calibration fitting.

See "Wiring—Controller and Sensor" on page 6 for detailed instructions.

#### Option 2

Locate Sensor separate from Controller using a Junction Box.

The Controller is located near eye-level. Conduit is run from the Controller to the Sensor. A Junction Box is used to connect the conduit from the Controller to the Sensor. A Calibration Cover is slipped onto the Sensor to concentrate the gas. Tubing can be run from the side calibration fitting on the Sensor to a convenient location accessible for calibration gas to be applied.

See "Sensor Separation" on page 7 for detailed instructions.

### **WARNING:** ⚠

To compensate for distance when remotely calibrating (sensor wired for separation), decrease the tubing diameter or increase the calibration gas flow rate between gas canister and sensor. Always confirm calibration by applying gas at the sensor (not separated).

**Figure 1:** Locate Sensor/Controller

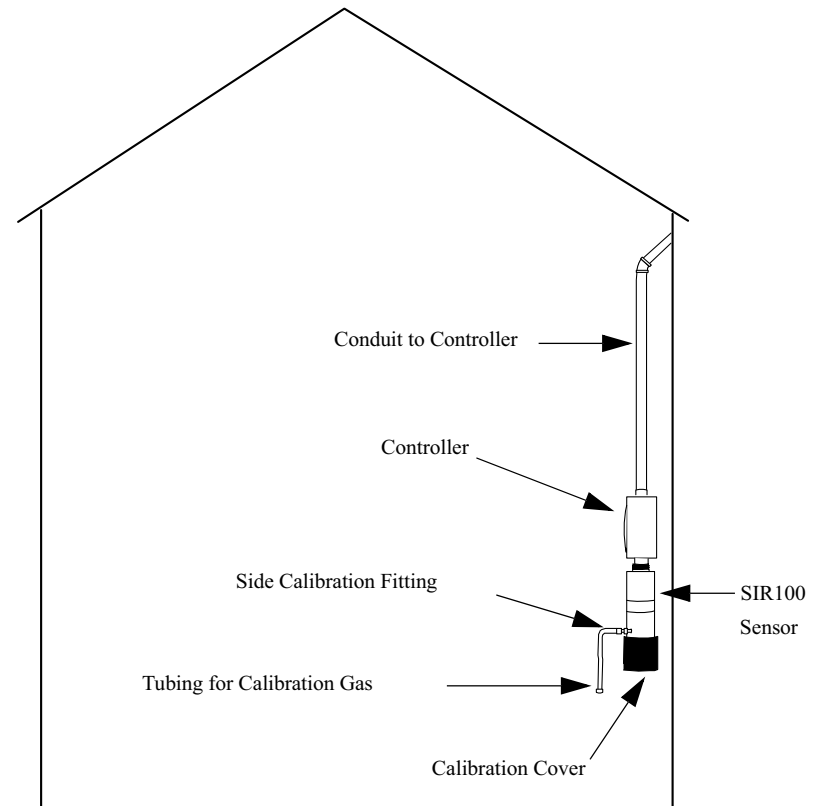

**TIP:** The Calibration Cover (CC-SIR100-SEP) prevents air circulation affecting the Calibration process and concentrates the gas during calibration.

**Figure 2: Dimensional Drawings**

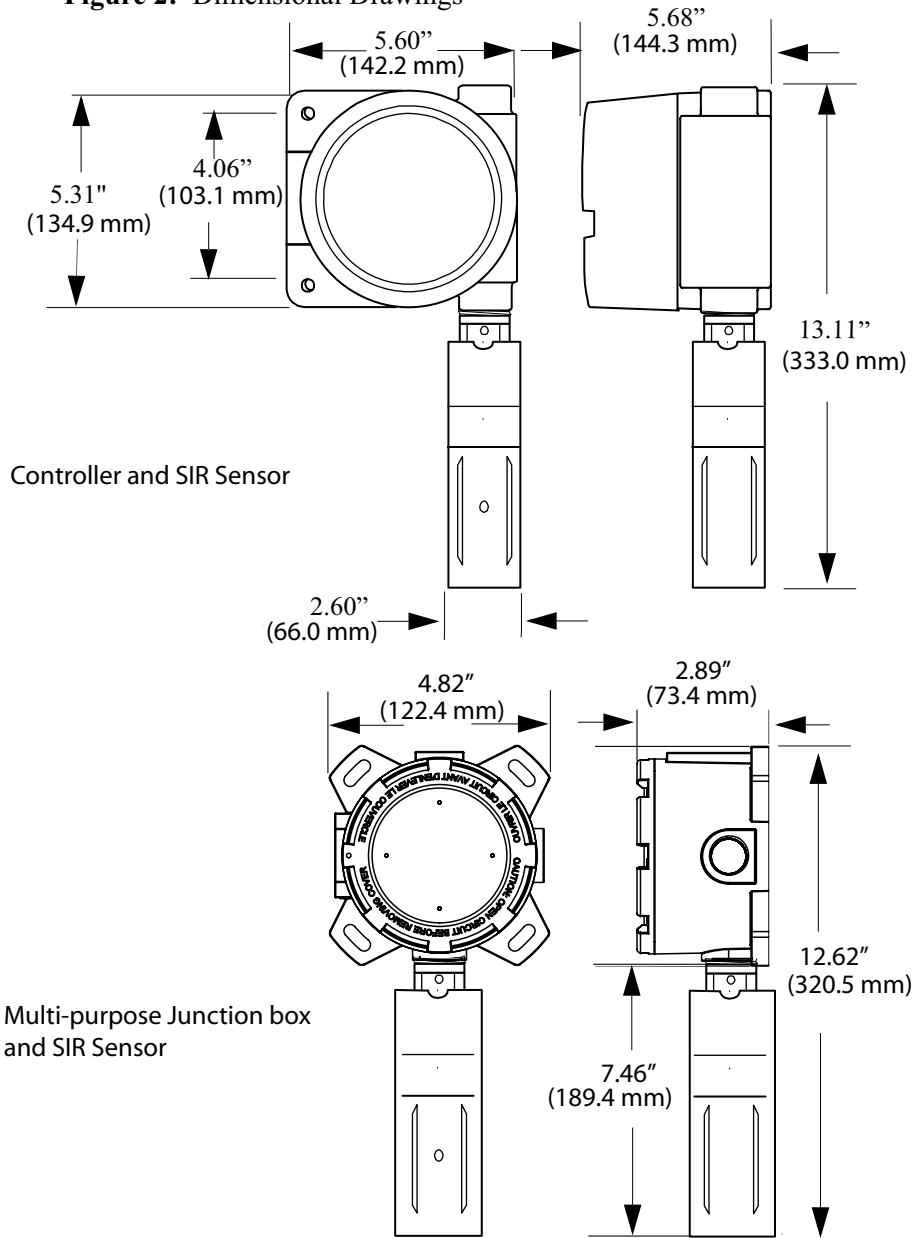

## STEP 2 — INSTALL

### UNPACK

Carefully remove all components from the packaging. Check components against the enclosed packing list and inspect all components for obvious damage such as broken or loose parts.

If you find any components missing or damaged, notify the representative or Net Safety Monitoring immediately.

**Figure 3: Components**

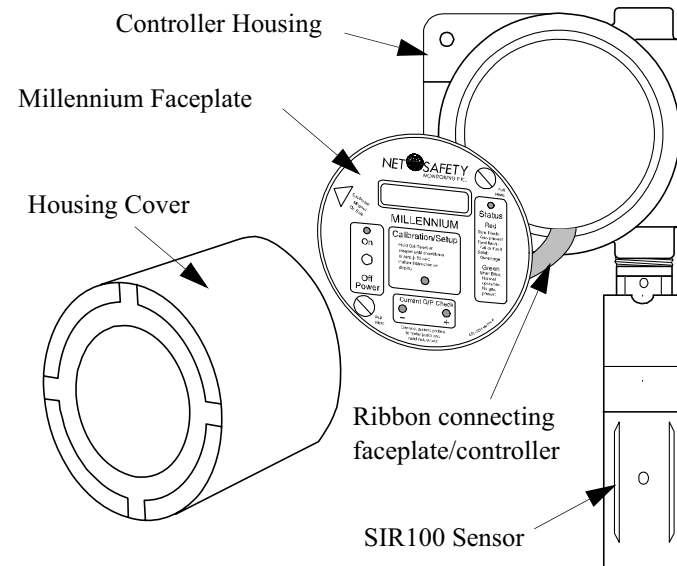

### External Equipment

It is necessary that reliable monitoring and indicating devices or systems be connected to the detector. These devices must be designed to produce clear visual and audible danger signals when high signal levels occur.

**Note:** A Certified Junction Box is used when Sensor and Controller are separated. Refer to **MAN-0081** for terminal designation.

## Mount

The Controller should be mounted near eye-level and be easily accessible for calibration and maintenance purposes. The Sensor should be placed where gas is likely to accumulate.

Ensure all devices are securely mounted, taking into consideration all requirements.

Use the Face Rotation Option to mount the Millennium Controller at a different orientation (refer to "Face Rotation Option" on page 20 for detailed instructions).

## STEP 3 — WIRE

### FIELD INSTALLATION

**WARNING:**  Wiring codes and regulations may vary. Wiring must comply with applicable regulations relating to the installation of electrical equipment in a hazardous area and is the responsibility of the installer. If in doubt, consult a qualified official before wiring the system.

- If the 4-20 mA signal is not used, connect a jumper between the 4-20 terminal and the Common terminal.
- The use of shielded cable is highly recommended for signal, input, output and power wires to protect against interference caused by extraneous electrical or electromagnetic 'noise'.
- In applications where the wiring cable is installed in conduit, the conduit must not be used for wiring to other electrical equipment.
- The maximum distance between the Sensor and Controller is limited by the resistance of the connecting wiring, which is a function of the gauge of the wire being used.
- When developing a RS-485 chain of devices, the last device in the chain requires end of line termination.
- RS-485 connection 2-wire, multipoint serial line.

## SEAL

- Water-proof and explosion-proof conduit seals are recommended to prevent water accumulation within the enclosure.
- Seals should be located as close to the device as possible and not more than 18 inches (46 cm) away.
- Explosion-proof installations may require an additional seal where conduit enters a non-hazardous area. Ensure conformity with local wiring codes.
- When pouring a seal, use a fibre dam to assure proper formation of the seal. Seals should never be poured at temperatures below freezing.
- The jacket and shielding of the cable should be stripped back to permit the seal to form around the individual wires. This will prevent air, gas and water leakage through the inside of the shield and into the enclosure.
- It is recommended that explosion-proof drains and conduit breathers be used. In some applications, alternate changes in temperature and barometric pressure can cause 'breathing' which allows moist air to enter and circulate inside the conduit. Joints in the conduit system are seldom tight enough to prevent this 'breathing'.

**Note:** Seals are not required for all Class 1 Division 2 locations in Canada. However, to fully avoid any exposure, the use of seals are still recommended, especially for installations that use high-pressure or steam cleaning devices in proximity to the controller and/or sensor.

### Connecting Wires

1. Use a small screw driver to gently press down and hold the spring connector open.
2. Insert appropriate wire into open connector hole.
3. Release screw driver to secure wire.

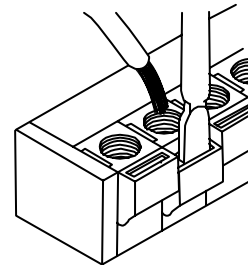

## Board Assembly

There are three different fixed boards, two optional relay boards and an optional Modbus board which make up the PCB Assembly. Depending upon requirements, either a Electromechanical or Solid State Relay Board module can be used. Boards are field replaceable. Simply loosen the three locking standoffs, remove one board, insert the other board and tighten screws.

**Note:** Boards are susceptible to ESD. Refer to Appendix A, "Electrostatic Sensitive Device (ESD)", on page 21.

**Figure 4:** Millennium Modular Boards

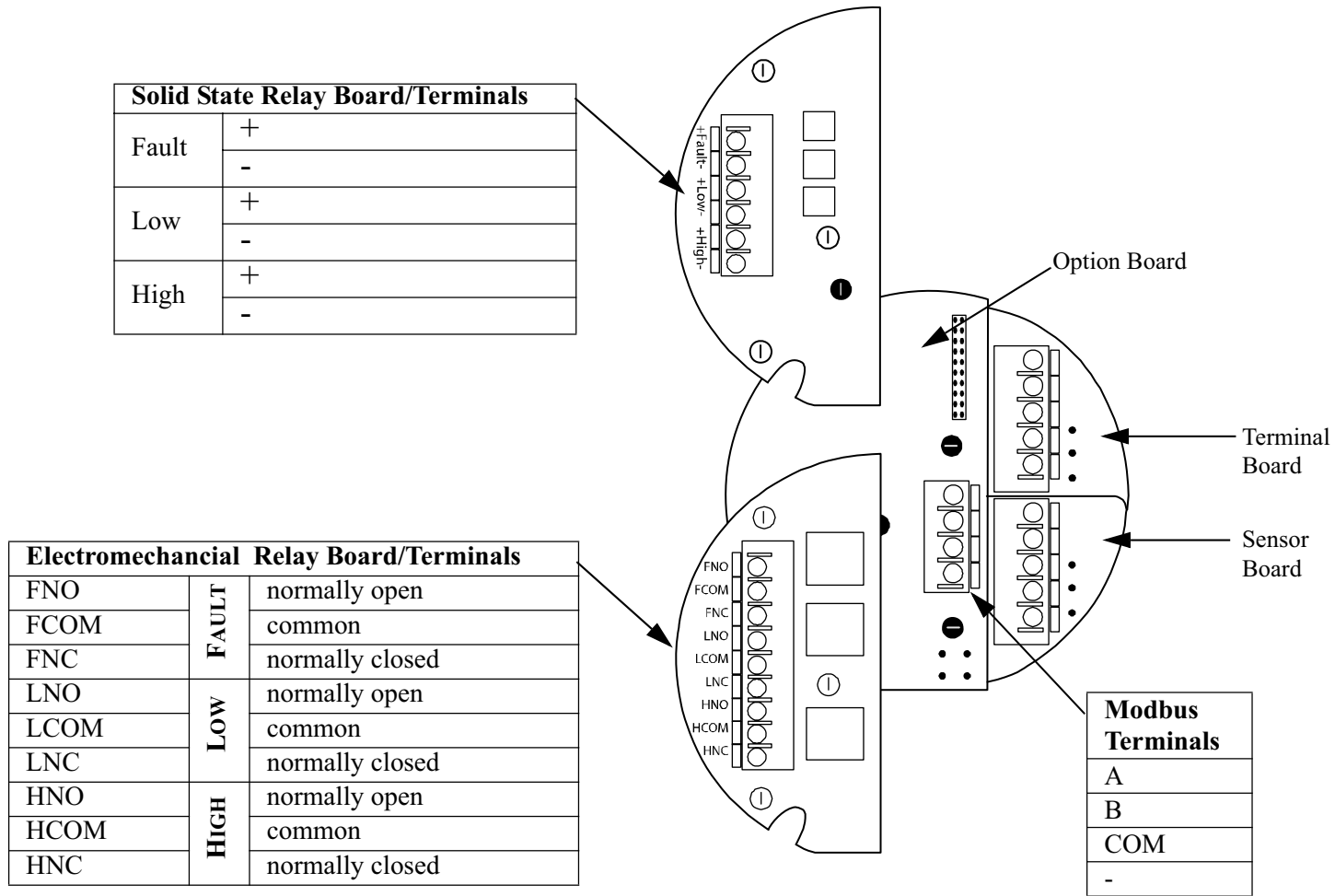

**Figure 5:** Wiring—Controller and Sensor

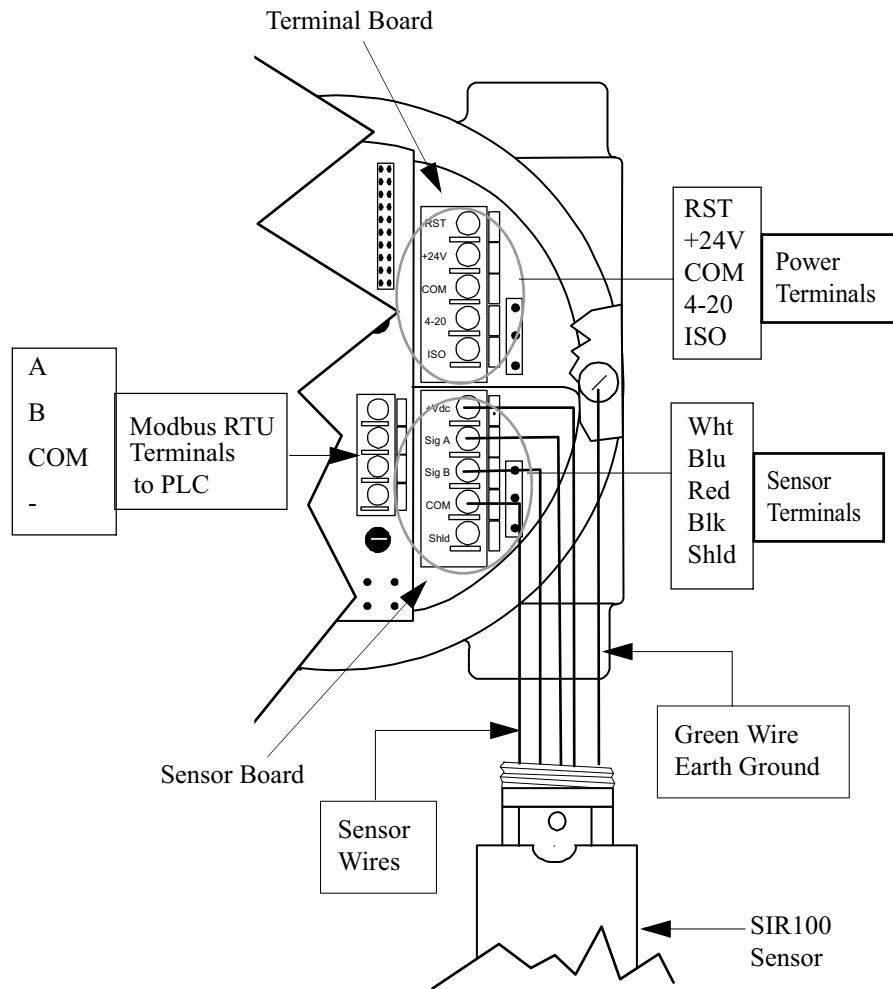

**Note:** If the 4-20 mA signal is not used, connect a jumper between the 4-20 terminal and the COM terminal on the Terminal Board.

## SENSOR AND CONTROLLER

### **WARNING:** ⚠

Power to the unit must be OFF before wiring.

**Note:** The Sensor may be factory installed to the Controller. If so, you need only connect the Power Terminals.

4. Remove the Controller's Housing Cover.
5. Connect the Sensor to the Sensor Terminals (if necessary) and the Output Terminals to the output signal wires.

**Table 1:** Controller/Sensor Terminal Connections

Sensor Terminals		Power Terminals	
Sensor Wire	Controller (Sensor Board)	Controller (Terminal Board)	Power Connections
White	= +Vdc	RST	= Remote Reset
Blue	= Sig A	+24V	= Power (+)
Red	= Sig B	COM	= Power (-)
Black	= COM (-)	4-20	= Current Loop Output
Shield	Shld	ISO	= +24 V isolated 4-20 power

**Note:** For Sensor Separation instructions, see Figure 6, "Wiring—Sensor Separation", on page 7.

6. Replace the Controller's Housing Cover.
7. Turn Controller On.
8. Ensure display reads **start delay**, Status LED is Red Slow Flash and current output displays 3.0 mA. This is the start-up delay sequence which will last approximately 90 seconds.

### RS-485 Communication

Connect devices in a chain via the Modbus terminals. The last device in the chain requires end of line termination (refer to "MODBUS Termination" on page 9).

## SENSOR SEPARATION

**Figure 6:** Wiring—Sensor Separation

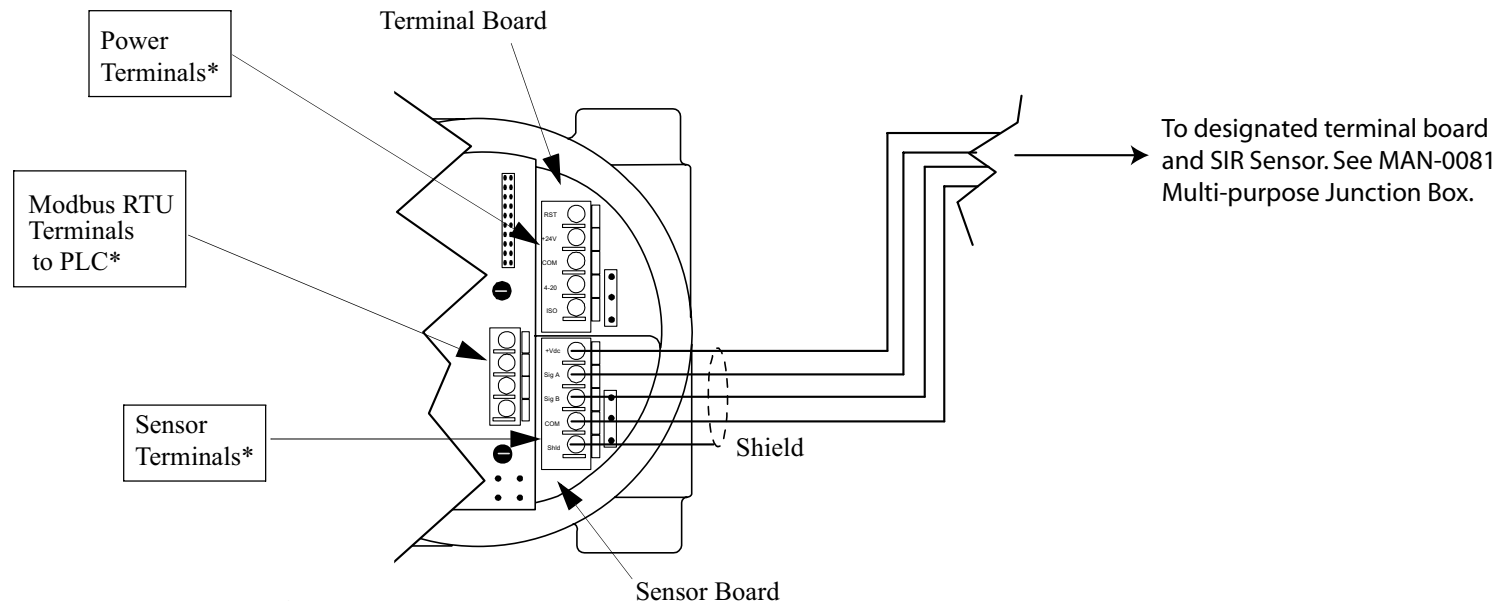

As the Sensor must be located where gas is likely to accumulate and the Controller where it can be easily reached, it is often necessary to “separate” the Controller and Sensor.

The Sensor separation kit (SEP) is composed of a junction box and terminal strip. Refer to the Net Safety Multi-purpose Junction Box(**MAN-0081**) for terminal designation when wiring for sensor separation.

Shielded copper instrument wire (minimum 18 AWG) should be used for separations up to 500 feet. Shielded copper instrument wire (minimum 16 AWG) should be used for separations up to 2000 feet. Consult the factory if a greater separation distance is required.

Ensure that the appropriate wire is used for Class 1/Division 1 hazardous applications.

**Note:** If the 4-20 mA signal is not used, connect a jumper between the 4-20 terminal and the COM terminal on the Terminal Board.

### **WARNING:**

To compensate for distance when remotely calibrating (sensor wired for separation), decrease the tubing diameter or increase the calibration gas flow rate between gas canister and sensor. Always confirm calibration by applying gas at the sensor (not separated).

## NON-ISOLATED/ISOLATED WIRING

### Terminal Connection

**Figure 7:** Non-isolated Terminal Connection

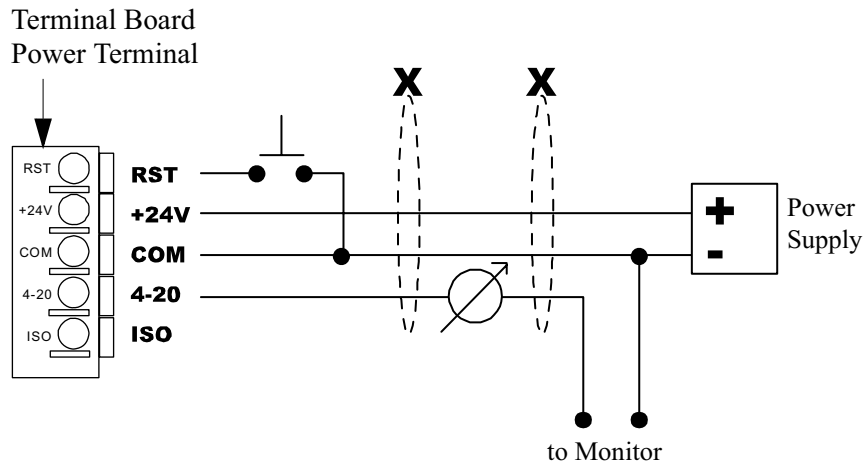

**Figure 8:** Isolated Terminal Connection

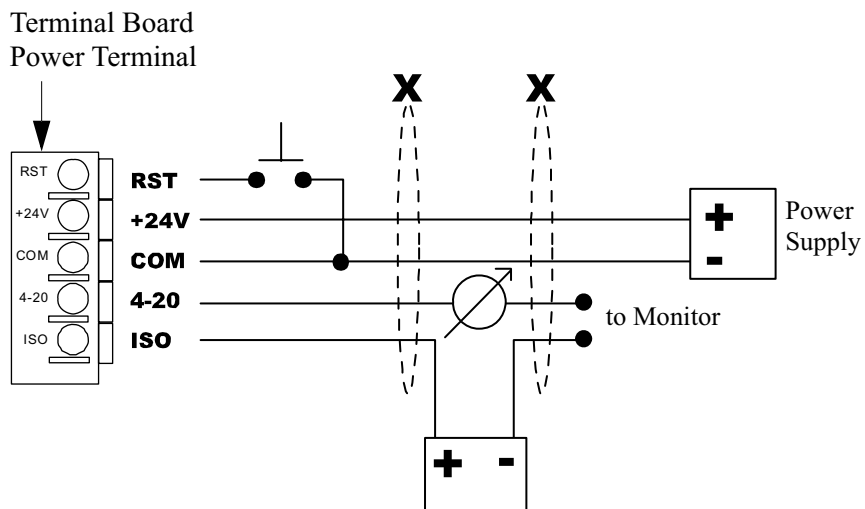

### Current Output

To set an isolated current output, simply move the Jumper (shorting jack) to either the isolated or non-isolated current position (refer to Figure 9, "Jumper Positions", on page 8).

**Note:** Unless otherwise specified, all models ship with non-Isolated current output.

**Figure 9:** Jumper Positions

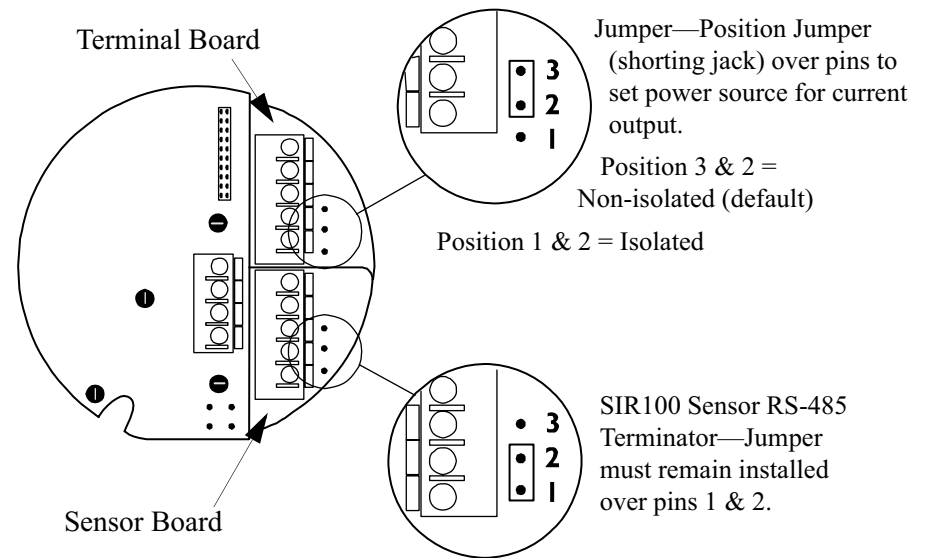

## REMOTE RESET

The Millennium can be set for remote reset. A normally open Push Button Switch must be connected between the RST and the COM terminals on the Terminal Board and the Relay Option Latch Status must be set to **Latching**.

**Figure 10:** Remote Reset

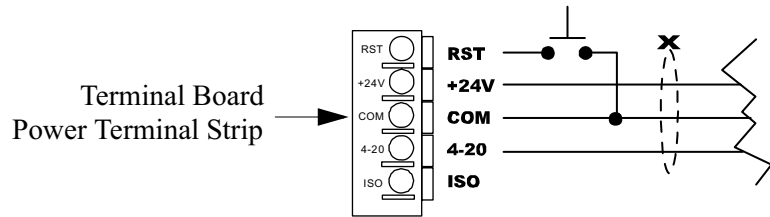

## MODBUS TERMINATION

Devices are networked in a daisy chain. The device located at the end of the chain requires end of line termination. Place both jumpers over the pins, as shown in Figure 11, "Modbus Termination Jumpers", on page 9, for end of line termination.

**Figure 11:** Modbus Termination Jumpers

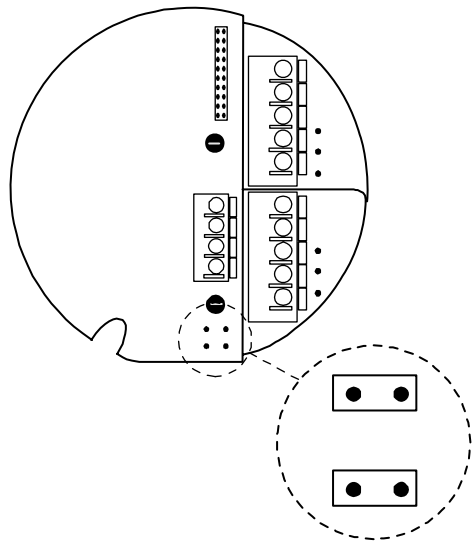

## STEP 4 — OPERATE

The Controller faceplate contains most functional elements of the user interface. Below is a description of that functionality.

**Figure 12: Controller Functionality**

**Magnetic Reed Switch** - provides non-intrusive access for programming, calibrating and resetting.

-Place magnet against Housing (where indicated) for less than one second to initiate a basic system reset (clear a latched alarm) and make selections.

-Place magnet against Housing (where indicated) and hold to program, view current settings and calibrate.

Refer to "Magnetic Reed Switch" on page 12 for further information.

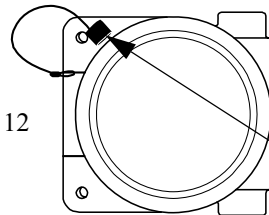

**Scrolling 8-character display** - provides various status messages and prompts. Refer to "Status LEDs, Display Messages and Current Loop" on page 11.

**Pull Here knob** - unscrew the two screws and gently pull to remove faceplate. Removal allows access to terminal boards. The faceplate remains attached by the ribbon cable.

**Status Light (Red and Green)** - indicates status of unit. Refer to "Status LEDs, Display Messages and Current Loop" on page 11 for detailed explanation of states/status.

**ON/OFF Switch** - used to turn Controller on and off. Housing must be removed to access.

**Pull Here knob** - unscrew the two screws and pull to remove faceplate. Removal allows access to PCBs. The faceplate remains attached by the ribbon cable.

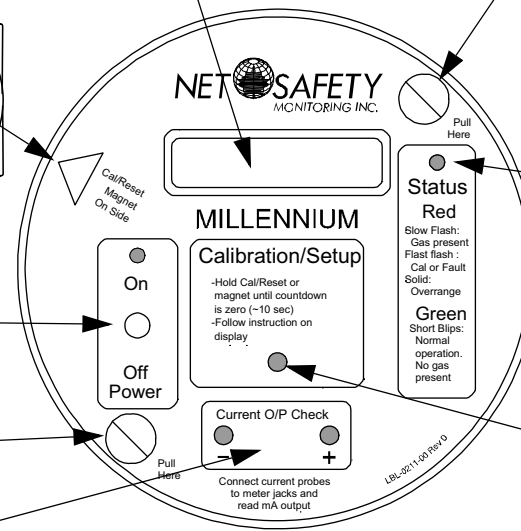

**Calibration Button** - provides intrusive access for programming, calibrating and resetting.

-Push for less than one second to initiate a basic system reset (clear a latched gas alarm) and make selections.

-Push and hold to program, view current settings and calibrate.

Refer to "Calibration Button" on page 12 for further information.

**Current Test Jacks** - to take current loop measurements use the following procedure:

-Insert your current meter leads into the Test Jacks.

-Set external devices to bypass, if necessary, to avoid unwanted alarm response

-Review current loop measurements.

Refer to "Current Loop Measurement (Test Jacks)" on page 12 and Table 2, "Status LEDs, Display Messages and Current Loop", on page 11.

**Table 2:** Status LEDs, Display Messages and Current Loop

State	Current O/P	Status LED		Display
		RED or GREEN		
Calibrate Sensor Set Relay Options Review Settings	3.0 mA	n/a		n/a
Normal operation	4.0 mA		Blip/ blink	00 %LEL
Start-up delay (90 sec)	3.0 mA	Slow flash		Start Delay
Access Main Menu	3.0 mA		Solid	Switch On 10-0
Memory Error (contact factory)	2.5 mA	Slow flash		Memory Error
White, Blue, Red or Black Sensor lead open	2.5 mA	Slow flash		Sensor Fault
Auto zero set	3.0 mA		Solid	Setting zero
Apply calibration gas	3.3 mA	Fast flash		Apply 50% Span
Span is set, remove gas	3.6 mA		Solid	Remove gas
Return to normal operation	3.6 mA		Solid	Cal. Complete
Gas present	>4.0-20.0 mA	Blip/ blink		1 to 100% full Scale
Calibration procedure failed/Sensor failed	3.0 / 3.3 mA	Flash	Flash	Fail Cal

### RTU Registers

Register 40001 = LEL output (read only)

Register 40002 = RTU Status (read only)

Register 40101 = Reset latched relays (write)

**Table 3:** RTU Status Register (40002) Read Only (binary)

RTUstat_fault	0x0001	fault (sensor..)
RTUstat_low_alarm	0x0002	low alarm tripped
RTUstat_high_alarm	0x0004	high alarm tripped
RTUstat_low_alarm_latched	0x0008	low alarm latched
RTUstat_high_alarm_latched	0x0010	high alarm latched
RTUstat_powerUp	0x0080	power up delay
RTUstat_cal_cycle	0x0100	calibration cycle in progress
RTUstat_zeroing	0x0200	
RTUstat_apply_span_gas	0x0400	
RTUstat_calibrating	0x0800	
RTUstat_remove_gas	0x1000	
RTUstat_cal_complete	0x2000	
RTUstat_mem_error	0x4000	memory error

### Calibration Button

The Calibration Button provides access to the Millennium’s Main Menu, which in turn allows calibration and options to be reviewed and set. Refer to Figure 12, "Controller Functionality", on page 10 for more information.

- **Press and hold** the Calibration Button to Calibrate and access Main Menu.
- **Briefly press** to make a selection (select **YES?**).

**WARNING:** 

Opening the Controller’s Housing should be avoided when the presence of gas is possible (when in a hazardous environment). Do not power up the system, with the Housing removed, unless the area has been de-classified.

### Magnetic Reed Switch

The Magnetic Reed Switch is provided to avoid opening the Housing in an environment where gas may be present. The Magnetic Reed Switch functions in the same manner as the Calibration Button but in a non-intrusive manner. Refer to Figure 12, "Controller Functionality", on page 10 for more information.

Attached to the side of the Controller is a magnet:

- **Place and hold** the magnet to the Controller’s Housing (10 o’clock position) to Calibrate and access Main Menu.
- **Briefly place** the magnet to the Controller’s Housing (10 o’clock position) to make a selection (select **YES?**).

### Power Up

Turn power switch On. A 90 second warm-up routine will begin. The display reads **Start Delay Millennium Net Safety**, Status LED is Red Slow Flash and current output displays 3.0 mA.

When power is applied, the system is automatically tested to ensure proper functionality.

After warm-up, the Controller will enter normal operation, the display reads 00 **%LEL**, Status LED will Green Blip/blink and analog output will change to 4.0 mA.

### Current Loop Measurement (Test Jacks)

Use a standard meter to measure current loop during various states. The Controller’s Housing cover must be removed to access the Test Jacks.

Refer to Table 2, “Status LEDs, Display Messages and Current Loop,” on page 11 for a detailed list and Figure 12, "Controller Functionality", on page 10 for more information.

### Status LED

The Status LED will remain solid, flash, blip and/or blink, in either Red or Green, to indicate various states. Refer to Table 2, “Status LEDs, Display Messages and Current Loop,” on page 11 for a detailed list.

## THE MAIN MENU

The Main Menu provides access to various functional settings and viewing of current settings.

- Calibrate Sensor.
- Review Relay Settings (optional) - Review the current Fault, Low and High alarm settings. This is a read only section.
- Set Relay Options (optional) - Set the Low and High alarm settings.
- Select Gas Curve (methane or propane).
- Select a display language - English, Spanish or French.
- Select Modbus Options.

**Note:** The current output will drop to 3.0 mA while in the Main Menu.

### Accessing the Main Menu

There are two ways to access the Main Menu:

- Calibration Button found on the faceplate (the Housing cover must be removed to access)
- Magnetic Reed Switch (a magnet must be used to activate)

### Main Menu Functionality

1. Ensure that the Controller has been turned on and no fault is present.
2. Hold the magnet against the Reed Switch or press and hold the Calibration Button until the message **Switch On** displays and the countdown (10 to 0) finishes.
3. An option will scroll across the display followed by the prompt **YES?**.
4. To select an option, momentarily place the magnet to the Reed Switch or press the Calibration Button at the **YES?** prompt.
5. If you do not wish to select that option wait until the next option appears and then select **YES?**.
6. A selection is acknowledged with a flashing **YES**.
7. If no option is selected, the Controller returns to **00 %LEL** (normal operation).

## STEP 5 — CALIBRATE

### CALIBRATION PROCEDURE

**WARNING:** The calibration procedure requires about 5 minutes to complete. If gas is not applied at the appropriate time, a calibration failure may occur (refer to "Calibration Failure" on page 14 for specific information).

For accurate performance, the Millennium should be calibrated using 50% span of the specific gas of concern. The concentration of gas, corresponding to 100% of full scale, is converted to a linear 4 to 20 mA output signal which can be powered from the primary dc supply of the instrument. Power up the unit for at least 4 hours BEFORE first calibration.

**Note:** Air movement, drafts and wind can cause dilution of calibration gas flow which can cause an erroneous calibration and inaccurate performance. To avoid this, use a Calibration Cover to cover the slots on the Sensor. The cover **MUST** be removed for normal operation. When slots are covered, inject calibration gas at a rate of 1.0 litre per minute or greater; when not covered, ensure area is free of drafts/wind and inject calibration gas at a rate of 3.0 litres per minute or greater.

The following calibration procedure should be followed to ensure an accurate correlation between the 4 to 20 mA output signal and the gas concentration.

**Figure 13:** Calibration Procedure

Display Shows	Calibrate Sensor YES?	Setting Zero	Apply 50% Span	Calibrating	Remove Gas	Cal Complete
<b>Action</b>	Select <b>YES?</b>	Apply clean (zero air)	Apply specific gas		Remove gas	Apply clean air to purge system



### Calibration Failure

If the calibration procedure fails, the display shows **Fail Cal**, the Status LED alternates Red/Green flashes and the analog output changes back and forth from 3.0 to 3.3 mA.

The unit remains in a failed state until manually reset. After the Manual Reset, the unit will return to normal operation based on previous calibration values. See "Manual Reset" on page 18 for instructions.

### Calibration Procedure

The unit can be set up to detect Methane or Propane. To determine the gas to be detected go to "Select Gas Curve" option in the menu and make the selection, then calibrate with the target gas. See "Select Gas Curve" option on page 16.

1. Confirm successful power up of Controller—LED Green Blip/blink every 2 seconds; no fault indicated.
2. Flow certified ZERO AIR at a rate of 1.0 litre per minute to the calibration nipple/fitting, when using the Calibration Cover. If separated or not using the Calibration Cover, a rate of at least 3.0 litres per minute is recommended.
3. Press and hold the Calibration Button or use the Reed Switch to access the Main Menu and wait for countdown (10-0) to complete.
4. When **Calibrate Sensor YES?** displays, use the Calibration Button or Reed Switch to select **YES?**  
Selection will be confirmed by a flashing **YES**.
5. When **Setting Zero** displays apply clean air.
6. Wait for **Apply 50% LEL** to display and apply specific gas. If in windy conditions and using a Calibration Cover, apply at a rate of 1.0 litre per minute otherwise 3.0 litres per minute is recommended.
7. The display will show **Calibrating** as gas detected.
8. Remove span gas when the message "**Remove Gas**" displays (Status LED Green solid and 3.6 mA output).
9. The message **Cal Complete** will display when calibration is complete.
10. Apply zero gas (clean air) again to purge system.

**Note:** Always apply test gas after calibration to verify operation.

## STEP 6 — MONITOR

### REVIEW RELAY SETTINGS

This is a **read-only mode**; changes cannot be made.

**Step 1:** Press and hold the Calibration Button or the magnet to the Reed Switch to enter the Main Menu; wait for the countdown, from 10 to

0, to end.

**Step 2:** When **Review Relay Settings** displays press the Calibration Button or use the Reed Switch to select. The flashing **YES** confirms the selection.

**Step 3:** The Fault Alarms are **fixed (Energized / Non-Latching)** and display first. Then the Low Alarm level, coil and latch status display, followed by the High Alarm level, coil and latch status.

**Step 4:** At this point, the option to **Set Relay Options YES?** is displayed.

### SET RELAY OPTIONS

Use to set the alarm level, coil status and latch status for the Low and High relays (Fault Alarm is fixed).

**Table 4:** Default Relay Settings

Millennium Model Number	Alarm Levels			Coil Status			
	Low	High	Fault	Latching	Non Latching	Energized	De-energized
MLP-A/AR/AD	20%	40%	Energ./Non-latching		*		*

## Setting Relay Options

There are two settings for Relay Options: Low and High. The Fault Relay is fixed as Energized/Non-latching and cannot be changed. The low alarm level, coil energization and latch status for low alarm are set first; high alarm level, coil energization and latch status for high alarm are then set. All ranges are in %LEL.

- Step 1:** When **Set Relay Options YES?** displays press the Calibration Button or use the Reed Switch to select. The flashing **YES** confirms the selection.
- Step 2:** The message **Set Low** displays. Low Alarm set-points are then displayed in increments of 5 (5 to 95).
- Step 3:** When the required level displays, press the Calibration Button or use the Reed Switch to select. The level selected will flash to confirm the selection.
- Step 4:** The message **Coil Status** displays. The display then shows **Energized YES?** and then **De-Energized YES?**.
- Step 5:** Press the Calibration Button or use the Reed Switch to select. The flashing **YES** confirms the selection. If no selection is made, Coil Status option is repeated.
- Step 6:** The message **Latch Status** displays. The display then shows **Latching YES?** and then **Non-Latching YES?**.
- Step 7:** Press the Calibration Button or use the Reed Switch to select. The flashing **YES** confirms the selection. If no selection is made, Latch Status option is repeated.
- Step 8:** The message **Set High** displays. The High Alarm level cannot be set to a value lower than the Low Alarm level (as set in Step 3), nor higher than the maximum of 100% LEL. The High Alarm level is displayed in increments of 5 **greater** than the Low Alarm level (as set in Step 3).
- Step 9:** Repeat Steps 3 through 7 to complete the High Alarm level, coil and latch status settings.

**Note:** If no selection is made, a 5 minute timer expires, in which case the unit returns to normal operation.

## SELECT GAS CURVE

Steps to set up target gas (Methane or Propane).

- Step 1:** Press and hold the Cal/Reset button or use the magnet to access the Main menu and wait for countdown(10-0) to complete. Skip / ignore "Calibrate sensor" option and wait for "Select Gas Curve" option.
- Step 2:** When the message **Select Gas Curve YES?** displays press the Calibration Button or use the Reed Switch to select. The flashing **YES** confirms the selection.
- Step 3:** The message **Methane %LEL Yes?** displays. Use the Calibration Button or use the Reed Switch to select or wait for **Propane %LEL Yes?** to display and select.
- Step 4:** The flashing **YES** confirms the selection and will continue to flash for a few seconds. The Millennium display will shortly return to normal operation **00 %LEL**.
- Note:** If the gas curve is modified, the Millennium must be recalibrated (refer to "Calibration Procedure" on page 14).

## SELECT DISPLAY LANGUAGE

- Step 1:** When **Select Display Language YES?** displays press the Calibration Button or use the Reed Switch to select. The flashing **YES** confirms the selection.
- Step 2:** When the required language displays (**English, Espanol, Francais**) press the Calibration Button or use the Reed Switch to select. The flashing **YES** confirms the selection.
- Note:** Factory default is English.

## MODBUS OPTIONS

The digital RS-485 Modbus RTU protocol is used. There are two Modbus options: Node Address and Baud Rate.

### Node Address

Each device connected to the chain must be assigned a unique node address. The last number in the address is selected first.

- Step 1:** When **Modbus Setup? YES?** displays press the Calibration Button or use the Reed Switch to select.  
The flashing **YES** confirms the selection.
- Step 2:** The current node address will display **Node: 000**.
- Step 3:** Wait for the prompt **New Address? YES?** and press the Calibration Button or use the Reed Switch to select.
- Step 4:** Use the Calibration Button or Reed Switch to select each of three numbers in the new address:  
- select the last number in the address first: 0 thru 9.  
- select the next number in the address: 0 thru 9.  
- select the first number in the address last: 0 1 2.

### Baud Rate

The transmission speed must be defined.

- Step 1:** When **Modbus Setup? YES?** displays press the Calibration Button or use the Reed Switch to select.  
The flashing **YES** confirms the selection.
- Step 2:** After setting the Node Address, the current Baud Rate will display **xx.x BPS**.
- Step 3:** Wait for the prompt **New Baud Rate? YES?** and press the Calibration Button or use the Reed Switch to select.
- Step 4:** The available baud rates will display: **2400s, 4800s, 9600s, 14.4s, 19.2s, 28.8s, 38.4s, 57.6s**.
- Step 5:** Use the Calibration Button or use the Reed Switch to select baud rate when it displays.
- Step 6:** The flashing **YES** confirms the selection.

## ALARMS

### Sensor Fault

#### WARNING:

The fault detection circuitry does not monitor the operation of external response equipment or the external wiring to these devices. It is important that these devices be checked periodically to ensure they are operational.

Self-testing circuitry continuously checks for problems that could prevent proper response. When power is applied, the microcontroller automatically tests the system to ensure that it is functioning properly. During normal operation, it continuously monitors the signal from the internal sensor source. In addition, a "watchdog" timer is maintained to ensure the program is running correctly. When a system fault is detected, the Status LED will Red Slow flash, the displays shows **Sensor Fault** and analog output changes to 2.5 mA.

### Gas Present

When gas is present, **1 to 100% Full Scale** will display, the analog output switches to between 4 and 20 mA and the Status LED Blip/blinks Red.

### Sensor Life

Depending on various factors, sensor response may slowly deteriorate over a period of years. If calibration becomes impossible for any reason, the display will show **Fai1 Cal**, the analog output will switch repeatedly between 3.0 mA and 3.3 mA and the Status LED alternates Red and Green flashes.

## RESET

### Manual Reset

A Manual Reset is required after a calibration failure or to clear a latched relay alarm. Simply place and hold the magnet against the Reed Switch or press and hold the Calibration Button for 3-5 seconds. The unit will return to normal operation using previous calibration values.

### Remote Reset

If Relay Option is set to **Latching** (refer to "Setting Relay Options" on page 16) and an open Push Button Switch is connected between the RST terminal and the COM terminal on the Terminal Board, Remote Reset is possible. Also refer to "Remote Reset" on page 9 for details.

## OUTPUTS

### Relay

**Note:** The fault relay output is not used to activate an automatic shutdown procedure. The fault output indicates a potential problem with the Controller not an alarm condition.

Standard electro-mechanical relay outputs have Form C SPDT contacts rated 5 Amps at 30 V dc/ 250 V ac. Three relay outputs are available; one for Fault; one for Low alarm; and one for High alarm. All relays have normally open and normally closed contacts available at the output terminals.

The fault relay is set for normally energized operation and is non-latching. If a system fault is detected, the fault relay becomes de-energized. The fault relay is factory set and cannot be altered. The Low alarm and High alarm relays can be selected for either normally energized or normally de-energized operation and latching/non-latching.

## Modbus

Digital RS-485 Modbus RTU protocol is used.

Register 40001 = LEL output (read only)

Register 40002 = Status (read only)

Register 40101 = Reset latched alarms (write)

**Note:** Many registers are used by the controller. Please do not write outside the three registers.

## Current

A 4-20 mA dc current output is used to transmit the alarm status and fault codes to other devices. This output can be wired for isolated or non-isolated operation. A 4.0 mA output indicates normal operation; a 4.0 - 20.0 mA output indicates the presence of gas. Current output of 2.5 mA indicates the presence of a system fault.

## STEP 7 — MAINTAIN

### PERIODIC RESPONSE CHECK

Net Safety Monitoring recommends that a bump test be performed every 90 days to ensure continued functionality and accuracy of the detector. Full calibration is recommended when the sensor fails to meet acceptable accuracy standards. This involves the application of calibration gas to the sensor, then the observation of the response LEDs, analog output, and external monitoring equipment. Be sure to prevent unwanted response of external monitoring devices and equipment during this procedure. If the Millennium response to calibration gas is within the specified accuracy then it is not necessary to perform a calibration. For example, when 50% of full scale is applied, the response is expected to be between 11.5 mA (47% of full scale) and 12.5 mA (53% of full scale). An additional consideration is the accuracy tolerance of the calibration gas which may be + or - a few percent. If the calibration gas is + or - 10% of full scale then the reading may be from 10.7 mA (42% of full scale) to 13.3 mA (58% of full scale).

### TROUBLESHOOT

Response to the input should be checked and, if necessary, calibration should be performed whenever any of the following occur. Refer to "Calibration Procedure" on page 14 for calibration instructions.

- Sensor or transmitter is connected or disconnected
- Gas Curve is modified

The Millennium is not designed to be repaired in the field. If a problem should develop, first calibrate the device and carefully check for faulty wiring. If it is determined that the problem is caused by an electronic failure, the device must be returned to the factory for repair. Refer "How to Return Equipment" on page 19 for detailed instructions.

## HOW TO RETURN EQUIPMENT

A Material Return Authorization number is required in order to return equipment. Please contact Net Safety Monitoring at **(403) 219-0688** before returning equipment or consult our Service Department to possibly avoid returning equipment.

If you are required to return equipment, include the following information:

1. A Material Return Authorization number (provided over the phone to you by Net Safety).
2. A detailed description of the problem. The more specific you are regarding the problem, the quicker our Service department can determine and correct the problem.
3. A company name, contact name and telephone number.
4. A Purchase Order, from your company, authorizing repairs or request for quote.
5. Ship all equipment, prepaid to:

**Net Safety Monitoring Inc**  
2721 Hopewell Place NE  
Calgary, Alberta, Canada  
**T1Y 7J7**

6. Mark all packages: **RETURN for REPAIR**

Waybills, for shipments from outside Canada, must state:

**Equipment being returned for repair**  
**All charges to be billed to the sender**

Also, please ensure a duplicate copy of the packing slip is enclosed inside the box indicating item 1-4 along with the courier and account number for returning the goods.

**All Equipment must be Shipped prepaid. Collect shipments will not be accepted.**

Pack items to protect them from damage and use anti-static bags or aluminium-backed cardboard as protection from electrostatic discharge.

## SPARE PARTS/ACCESSORIES

**Table 5:** Part Numbering

Description	Net Safety Part Number
Calibration Cover for windy conditions	CC-SIR100-SEP
Magnet assembly	Magnet-1
Aluminium or Stainless Steel Junction box	JB-MPD-A/S
Terminal Connector Board	PCBA-0252D
IR Adapter Ring/Flame Arrestor Housing	SIR100-RING
IR Adapter Ring/Flame Arrestor Housing	SIR100-RING-SS
Replacement IR Sensor Assembly w/Methane & Propane curve, Aluminium housing	SIR100-100
Replacement IR Sensor Assembly w/Methane & Pentane curve, Aluminium housing	SIR100P
Replacement IR Sensor Assembly w/Methane & Propane curve, Stainless Steel housing	SIR100-100-SS
Replacement IR Sensor Assembly w/Methane & Pentane curve, Stainless Steel housing	SIR100-100P-SS

## FACE ROTATION OPTION

In some applications, it is necessary for the Millennium Controller to be mounted in a non-standard orientation. To accommodate such installations and ensure that the display will appear at the correct angle for viewing, the PCB Assembly can be rotated inside the Controller.

**Figure 14:** Non-standard Orientations

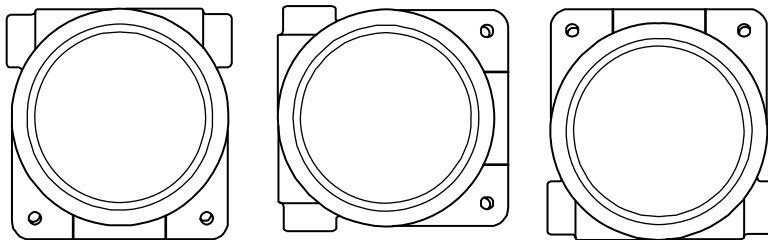

**Note:** Ensure orientation allows for connections and excess wire within Controller Housing.

## Rotate PCB Assembly

1. Remove the Controller's Housing Cover.
2. Turn the power to the detector off.
3. Unscrew both the knobs marked "Pull Here".
4. Lift Controller faceplate from Housing and allow to hang from ribbon cable.
5. Unscrew the two metal standoffs.
6. Carefully remove the PCB Assembly from the Housing.
7. The Rotator plate is secured to the bottom of the Housing and is accessible after the PCB Assembly has been removed.
8. Rotate the PCB Assembly to desired position and line up the standoffs with the mounting holes.
9. Insert standoffs in the appropriate horizontal or vertical mounting holes.
10. Tighten standoffs to secure PCB Assembly.
11. Replace faceplate and tighten "Pull Here" knobs.
12. Return power to detector and replace Housing Cover.

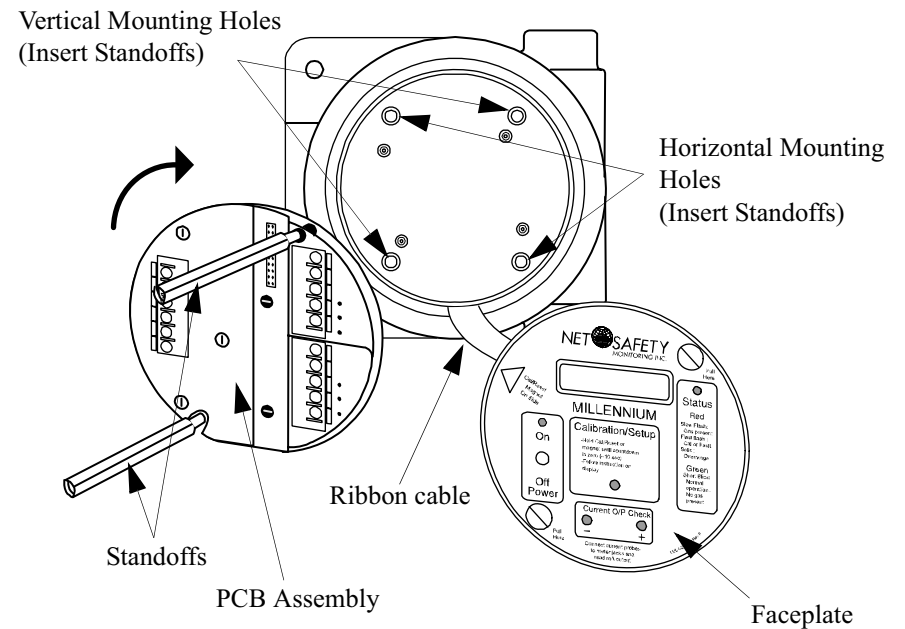

**WARNING:** See Appendix A, "Electrostatic Sensitive Device (ESD)", on page 21 for handling instructions of electronic components.

## **Appendix A:**

### **ELECTROSTATIC SENSITIVE DEVICE (ESD)**

Electrostatic discharge (ESD) is the transfer, between bodies, of an electrostatic charge caused by direct contact or induced by an electrostatic field.

The most common cause of ESD is physical contact. Touching an object can cause a discharge of electrostatic energy—ESD! If the charge is sufficient and occurs near electronic components, it can damage or destroy those components.

In some cases, damage is instantaneous and an immediate malfunction occurs. However, symptoms are not always immediate—performance may be marginal or seemingly normal for an indefinite period of time, followed by a sudden failure.

To eliminate potential ESD damage, review the following guidelines:

- Handle boards by metal shields—taking care not to touch electronic components
- Wear grounded wrist or foot straps, or ESD shoes or heel grounders to dissipate unwanted static energy
- Prior to handling boards, dispel any charge in your body or equipment
- Ensure components are transported and stored in static safe packaging
- When returning boards, carefully package in the original carton and static protective wrapping
- Ensure ALL personnel are educated and trained in ESD Control Procedures

In general, exercise accepted and proven precautions normally observed when handling electrostatic sensitive devices.

A warning label is placed on the packaging, identifying product using electrostatic sensitive semiconductor devices.



## Appendix B: RESISTANCE TABLE

**Table 6:** Wire Resistance In Ohms

Distance (Feet)	AWG #20	AWG #18	AWG #16	AWG #14	AWG #12	AWG #10	AWG #8
100	1.02	0.64	0.40	0.25	0.16	0.10	0.06
200	2.03	1.28	0.80	0.51	0.32	0.20	0.13
300	3.05	1.92	1.20	0.76	0.48	0.30	0.19
400	4.06	2.55	1.61	1.01	0.64	0.40	0.25
500	5.08	3.20	2.01	1.26	0.79	0.50	0.31
600	6.09	3.83	2.41	1.52	0.95	0.60	0.38
700	7.11	4.47	2.81	1.77	1.11	0.70	0.44
800	8.12	5.11	3.21	2.02	1.27	0.80	0.50
900	9.14	5.75	3.61	2.27	1.43	0.90	0.57
1000	10.20	6.39	4.02	2.53	1.59	1.09	0.63
1250	12.70	7.99	5.03	3.16	1.99	1.25	0.79
1500	15.20	9.58	6.02	3.79	2.38	1.50	0.94
1750	17.80	11.20	7.03	4.42	2.78	1.75	1.10
2000	20.30	12.80	8.03	5.05	3.18	2.00	1.26
2250	22.80	14.40	9.03	5.68	3.57	2.25	1.41
2500	25.40	16.00	10.00	6.31	3.97	2.50	1.57
3000	30.50	19.20	12.00	7.58	4.76	3.00	1.88
3500	35.50	22.40	14.10	8.84	5.56	3.50	2.21
4000	40.60	25.50	16.10	10.00	6.35	4.00	2.51
4500	45.70	28.70	18.10	11.40	7.15	4.50	2.82
5000	50.10	32.00	20.10	12.60	7.94	5.00	3.14
5500	55.80	35.10	22.10	13.91	8.73	5.50	3.46
6000	61.00	38.30	24.10	15.20	9.53	6.00	3.77
6500	66.00	41.50	26.10	16.40	10.30	6.50	4.08
7000	71.10	44.70	28.10	17.70	11.10	7.00	4.40
7500	76.10	47.90	30.10	19.00	12.00	7.49	4.71
8000	81.20	51.10	23.10	20.20	12.70	7.99	5.03
9000	91.40	57.50	36.10	22.70	14.30	8.99	5.65
10 000	102.00	63.90	40.20	25.30	15.90	9.99	6.28

**Note:** Resistance shown is one way. This figure should be doubled when determining closed loop resistance.

## Appendix C: SPECIFICATIONS

### SENSOR SPECIFICATIONS

- Operating Temperature Range: -40°C to +75°C (-40F to +167F)
- Weight: 0.9 Kg (2.0 lb)
- Enclosure Material: Powder Coated or Anodized Aluminum (optional stainless steel)
- Range of Detection: 0 to 100% LEL methane/propane
- Accuracy: ±3% LEL up to 50% LEL  
±5% LEL above 50% LEL

- Response Time: <5 seconds to T20  
<7 seconds to T40
- Linearity/Repeatability: ±3% LEL / ±2% LEL
- Certification: CSA and NRTL/C certified for hazardous locations. Class I, Division 1, Groups B, C and D. IEC Rating Ex d IIB+H2 T5. Performance certified to CSA C22.2 No. 152.

### CONTROLLER SPECIFICATIONS

MILLENNIUM	4-20 mA ANALOG OUTPUT <sup>1</sup>	4-20 mA with RELAY OUTPUT MODULE <sup>12</sup>	DIGITAL <sup>3</sup>
<b>Operating Temperature Range</b>	-40°C to +85°C (-40F to +185F)		
<b>Power Consumption</b> <b>24 V dc @ 50 Span</b>	Nominal 3.02 W Maximum 3.38 W	Nominal 3.36 W Maximum 4.5 W	Nominal 3.02 W Maximum 3.38 W
<b>Humidity Range</b>	0 to 100% Relative humidity, non-condensing		
<b>Operating Voltage Range</b>	10.5 to 32.0 V dc		
<b>Enclosure Material</b>	Powder coated Copper Free Cast Aluminum		
<b>Certifications</b>	CSA and NRTL/C certified for hazardous locations. Class I, Division 1, Groups B, C and D. Temperature Code T5. Rating Ex d IIB+H2 T5 (Class1, Zone 2, Group IIB+H2T5). Maximum operating ambient of 85°C. Enclosure Type 4X. Note: Electronics only-CSA and NRTL/C certified for hazardous locations Class I, Division 2 Groups A, B, C and D.		
<b>Weight</b>	3.5 Kg (7.7 lb)		
<sup>1</sup> 4 to 20 mA - Into a maximum loop impedance of 800 Ohms at 32 V dc or 150 Ohms at 10.5 V dc. Isolated or non-isolated loop supply. <sup>2</sup> Form C contacts rated 5 Amps at 30 V dc / 250 V ac. Selectable energized / de-energized, latching/non-latching configurable low and high alarms. Fault relay is factory set as energized, non-latching and cannot be modified. <sup>3</sup> Digital RS-485 Modbus protocol.			



*Distributed by:*  
*Net Safety Monitoring Inc.,*  
*2721 Hopewell Place NE*  
*Calgary, Alberta, Canada T1Y 7J7*  
*Telephone: (403) 219-0688 Fax: (403) 219-0694*  
*E-mail: [netsafe@net-safety.com](mailto:netsafe@net-safety.com)*  
*[www.net-safety.com](http://www.net-safety.com)*

---